

BMW 1er Limousine	F20	09/11 >>
BMW 3er Limousine	F30	02/12 >>
BMW 3er Touring	F31	09/12 >>
BMW 3er GT	F34	06/13 >>
BMW 4er Coupé	F32	09/13 >>

737201

748401

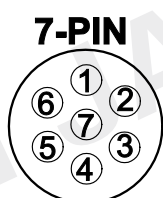
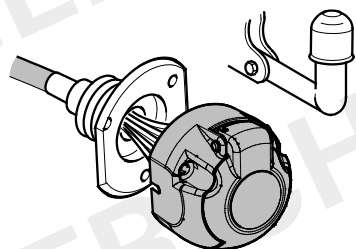

ISO 1724

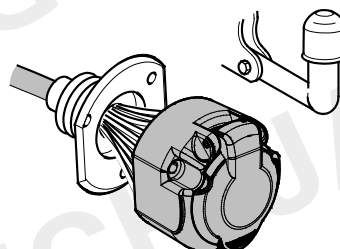

ISO 11446

- (D)** Einbauanleitung
- (GB)** Installation instructions
- (F)** Consignes de montage
- (NL)** Montagehandleiding
- (DK)** Montagevejledning
- (N)** Monteringsinstruksjon
- (S)** Installationsanvisning
- (FIN)** Asennusohje
- (I)** Istruzioni per il montaggio
- (E)** Instrucciones de montaje
- (P)** Instruções de montagem
- (GR)** Οδηγίες εγκατάστασης
- (CZ)** Návod k montáži

- (PL)** Instrukcja montażu
- (TR)** Montaj talimatı
- (H)** Beépítési útmutató
- (HR)** Upute o ugradnji
- (BUL)** Инструкция за монтаж
- (RO)** Instrucțiuni de montaj
- (RU)** Инструкция по монтажу и установке
- (LT)** Montavimo informacija
- (LV)** Iemontēšanas pamācība
- (EST)** Paigaldusjuhend
- (SLO)** Navodilo za vgradnjo
- (SK)** Montážny návod

<p style="text-align: center;">D</p>	<p>Hinweis:</p> <p>Vor Beginn der Montage sind folgende Hinweise zu beachten:</p> <p>Die Einbauanleitung ist vollständig durchzulesen. Der Einbau sollte nur von Fachpersonal mit entsprechenden Fachkenntnissen durchgeführt werden. Es müssen aktuelle Hinweise und Informationen der Fahrzeughersteller zu Um- und Nachrüstungen beachtet werden. Die Aus- und Einbauschnitte müssen anhand der aktuellen Reparaturleitfäden durchgeführt werden. Es muss sichergestellt sein, dass das Fahrzeug technisch für den Betrieb einer Anhängerkupplung geeignet ist. Der Fehlerspeicher des Fahrzeuges ist auszulesen und bei Bedarf ist die Software zu aktualisieren. Bei Funktionsproblemen ist die Fehlersuche auf ca. 0,5 Stunden zu begrenzen, kontaktieren Sie die E-Satz Helpline ✉ ekitsupport@erich-jaeger.de / ☎ 01805 537289</p>
<p style="text-align: center;">GB</p>	<p>Reference:</p> <p>The following information must be reviewed before beginning the assembly:</p> <p>The installation instructions are to be thoroughly read. The installation should be carried out by qualified personnel with the relevant technical knowledge. The vehicle manufacturers' current technical notices and information on retrofitting must be followed. The removal and replacement instructions found in the current repair manuals must be followed. It must be ensured that the vehicle is technically suitable for the installation of a trailer hitch. The vehicle fault memory must be read out and the software updated if necessary. In the event of functional problems, troubleshooting must be limited to about 0.5 hours, contact the E-Kit helpline ✉ ekitsupport@erich-jaeger.de / ☎ +49 (0)1805 537289</p>
<p style="text-align: center;">F</p>	<p>Remarque :</p> <p>Avant de procéder au montage, respecter les instructions suivantes :</p> <p>Lire impérativement l'instruction d'installation intégralement. L'installation doit être réalisée exclusivement par un personnel spécialisé disposant des connaissances professionnelles adéquates. Les instructions et les informations actuelles du constructeur automobile pour la transformation et le rééquipement doivent être respectées. Les phases de démontage et de montage doivent être réalisées au moyen des guides de réparation en vigueur actuellement. Il faut s'assurer que le véhicule est techniquement approprié à l'usage d'un dispositif d'attelage de remorque. Lire la mémoire de défauts du véhicule et mettre à jour le logiciel si nécessaire. S'il y a des problèmes de fonctionnement, limiter la recherche de défauts à env. 30 minutes et contacter l'Aide en ligne E-Set ✉ ekitsupport@erich-jaeger.de / ☎ 01805 537289</p>
<p style="text-align: center;">NL</p>	<p>Opmerking:</p> <p>Vóór begin van de montage moeten de volgende aanwijzingen in acht genomen worden: De inbouw-aanwijzing moet helemaal doorgelezen worden. De inbouw mag alleen van vakpersoneel met desbetreffende vakkennis uitgevoerd worden. Er moeten de actuele aanwijzingen en informatie van de voertuigproducent over ombouwingen en toerusting in acht genomen worden. De uit- en inbouwstappen moeten aan de hand van de actuele reparatieleidraad uitgevoerd worden. Er moet verzekerd zijn, dat het voertuig technisch voor het bedrijf van een aanhangwagenkoppeling geschikt is. Het foutengeheugen van het voertuig moet worden uitgelezen en indien nodig moet de software bijgewerkt worden. Bij werkingsproblemen moet de foutencontrole tot ca. 0,5 uur beperkt worden; neem contact op met de E-Satz Helpline ✉ ekitsupport@erich-jaeger.de / ☎ 0049(0)1805 537289</p>
<p style="text-align: center;">DK</p>	<p>Henvisning:</p> <p>Bemærk følgende anvisninger, inden du påbegynder monteringsarbejdet:</p> <p>Læs hele monteringsvejledningen igennem. Montering må kun foretages af faguddannet personale, der besidder den nødvendige kvalifikation. Aktuelle anvisninger og informationer fra køretøjets producent angående ombygning og eftermontering skal iagttages. De enkelte arbejds-skridt ved af- og påmontering skal udføres ifølge den aktuelle reparationshåndbog. Forvis dig om, at køretøjet er teknisk egnet til brug af anhængerkobling. Køretøjets fejlhukommelse skal udlæses og om nødvendigt skal softwaren opdateres. Ved funktionsproblemer skal fejlsøgningen begrænses til ca. 0,5 time, kontakt E-Satz Helpline ✉ ekitsupport@erich-jaeger.de / ☎ 01805 537289</p>
<p style="text-align: center;">N</p>	<p>Henvisning:</p> <p>Før man begynner monteringen må man ta hensyn til følgende merknader:</p> <p>Man må lese gjennom hele monteringsveiledningen. Monteringen må kun gjennomføres av fagpersonell med respektive fagkunnskaper. Man må ta følge de aktuelle merknadene og informasjonene fra kjøretøyprodusenten angående ombygging og modifisering. Monterings- og demonteringstrinnene må gjennomføres i henhold til den aktuelle retningslinjen for reparasjoner. Man må forsikre seg om at kjøretøyet er teknisk egnet for drift med tilhengerkopling. Feilminnet til kjøretøyet må leses og ved behov må programvaren aktualiseres. Ved funksjonsproblemer må feilsøket begrenses til ca. 0,5 timer, kontakt E-Satz Helpline ✉ ekitsupport@erich-jaeger.de / ☎ 01805 537289</p>

<p style="text-align: center;">S</p>	<p>Anm: Innan montering sker ska följande anvisningar beaktas:</p> <p>Den fullständiga monteringsanvisningen ska läsas igenom. Montering får bara utföras av fackpersonal med motsvarande fackkunskaper. Aktuella anvisningar och information från fordonstillverkarna gällande modifieringar och kompletteringar ska beaktas. Demonterings- och monteringsstegen ska utföras med ledning av de aktuella reparationsanvisningarna. Det ska säkerställas att fordonet är tekniskt lämpat för drift med dragkrok. Felminnet i fordonet ska läsas ut och vid behov måste programvaran uppdateras. Vid funktionsproblem ska felsökningen begränsas till ca 0,5 timme, kontakta reservdels-helpline ✉ ekitsupport@erich-jaeger.de / ☎ 01805 537289</p>
<p style="text-align: center;">FIN</p>	<p>Huomautus: Ennen asennusta on huomioitava seuraavat ohjeet:</p> <p>Asennusohje on luettava täydellisesti. Asennuksen saa suorittaa vain vastaavan pätevyyden omaava henkilöstö. Ota huomioon ajoneuvon valmistajan antamat muuttamista ja jälkivarustamista koskevat ohjeet ja tiedotteet. Purkamis- ja asennusvaiheet tulee suorittaa ajankohtaisia korjausohjeita noudattaen. Täytyy varmistaa, että ajoneuvo on teknisesti soveltuva perävaunun hinauskytkimen käyttöön. Ajoneuvon virhemuisti on tarkastettava ja tarpeen vaatiessa päivitettävä. Virrehaku on rajoitettava toiminto-ongelmien esiintyessä noin 0,5 tuntiin, ota yhteys E-Satz Helpline ✉ ekitsupport@erich-jaeger.de / ☎ 01805 537289</p>
<p style="text-align: center;">I</p>	<p>Avvertenza: Prima di procedere con il montaggio, osservare le seguenti indicazioni:</p> <p>Leggere le istruzioni di montaggio in ogni parte. Il montaggio deve essere effettuato solo da personale specializzato con conoscenze specifiche. Devono essere osservate le indicazioni e informazioni aggiornate del produttore del veicolo relativamente agli interventi di trasformazione e potenziamento. Gli interventi di montaggio e smontaggio devono essere eseguiti nel rispetto delle linee guida aggiornate relativamente alla riparazione. Si raccomanda di verificare che il veicolo sia tecnicamente idoneo per gestire un gancio di traino. La memoria dei guasti del veicolo deve essere letta e, se necessario, il software deve essere aggiornato. In caso di problemi di funzionamento, la ricerca di errori dovrebbe essere limitata a circa 0,5 ore. Contattare il centralino di assistenza per i fasci di cavi: ✉ ekitsupport@erich-jaeger.de / ☎ 01805 537289</p>
<p style="text-align: center;">E</p>	<p>Advertencia: Antes de iniciar el montaje se deben observar las siguientes indicaciones:</p> <p>Se deben leer completamente las instrucciones de montaje. El montaje sólo se debe realizar por personal especializado con los correspondientes conocimientos en la materia. Se deben respetar todas las observaciones e informaciones del fabricante del vehículo sobre reequipamientos. Los pasos de desmontaje y montaje se tienen que ejecutar según las directrices actuales de reparación. Se debe garantizar que el vehículo sea adecuado técnicamente para el servicio de un enganche para remolque. Se ha de seleccionar el almacenamiento de errores del vehículo y, si fuera necesario, actualizar el software. En caso de tener problemas con su funcionamiento, la búsqueda de errores está limitada a aprox. 0,5 horas, por lo que le recomendamos ponerse en contacto con el servicio de atención telefónica: ✉ ekitsupport@erich-jaeger.de / ☎ 01805 537289</p>
<p style="text-align: center;">P</p>	<p>Aviso: Antes do início da montagem deve-se observar os seguintes avisos.</p> <p>As instruções de montagem devem ser lidas por completo. A montagem só deve ser realizada por pessoal especializado com os respetivos conhecimentos específicos. Deve-se observar os avisos e informações atuais para ajustes e adaptações do produtor do veículo. Os passos da montagem e de prolongamento têm que ser realizados de acordo com as atuais diretivas de reparos. Deve-se garantir que o veículo é tecnicamente apropriado para o funcionamento com um acoplamento de reboque. A memória de avarias do veículo deve ser lida e, se necessário, o software atualizado. Em caso de problemas de funcionalidade, a pesquisa de erros deverá ser limitada para aprox. 0,5 hora; contacte a linha de assistência do jogo eletrónico ✉ ekitsupport@erich-jaeger.de / ☎ 01805 537289</p>
<p style="text-align: center;">GR</p>	<p>Υπόδειξη: Πριν αρχίσετε τη συναρμολόγηση προσέξτε τις ακόλουθες υποδείξεις: Διαβάστε όλες τις οδηγίες εγκατάστασης. Η εγκατάσταση πρέπει να γίνει μόνο από ειδικό προσωπικό με τις ανάλογες τεχνικές γνώσεις. Προσέξτε τις τελευταίες υποδείξεις και πληροφορίες των εργοστασίων των οχημάτων σχετικά με τις διαρρυθμίσεις και μεταρρυθμίσεις του εξοπλισμού. Τα βήματα εγκατάστασης και απεγκατάστασης πρέπει να εκτελεστούν σύμφωνα με τις τελευταίες οδηγίες επισκευής. Πρέπει να είστε βέβαιοι ότι το όχημα είναι κατάλληλο από τεχνικής πλευράς για την τοποθέτηση και λειτουργία κοτσαδόρου. Η μνήμη σφαλμάτων του οχήματος πρέπει να διαβαστεί και αν χρειαστεί, να γίνει ενημέρωση του λογισμικού. Σε περίπτωση προβλημάτων λειτουργίας να περιοριστεί η αναζήτηση σφαλμάτων σε περ. 0,5 δευτ., επικοινωνήστε με τη γραμμή υποστήριξης Helpline ✉ ekitsupport@erich-jaeger.de / ☎ 01805 537289</p>

<p>CZ</p>	<p>Pokyn:</p> <p>Před zahájením montáže je nutno dodržovat následující pokyny: Návod k montáži je nutno kompletně pročíst. Montáž by měl provádět pouze odborný personál s odpovídajícími odbornými znalostmi. Musíte dodržovat aktuální pokyny a informace výrobce k přestavbám a dodatečnému vybavení. Demontážní a montážní kroky musíte provádět podle aktuálních návodů k opravám. Musíte zajistit, aby bylo vozidlo technicky způsobilé pro provoz závěsného zařízení přívěsu. Vychtěte obsah paměti chyb vozidla a v případě potřeby aktualizujte software. Při problémech funkčnosti je třeba vyhledávání chyb omezit na cca 0,5 hodiny, kontaktujte Helpline E-Satz ✉ ekitsupport@erich-jaeger.de / ☎ 01805 537289</p>
<p>PL</p>	<p>Wskazówka:</p> <p>Należy przeczytać dokładnie i w całości instrukcję montażu. Montaż powinien zostać przeprowadzony przez wyspecjalizowany personel z odpowiednią wiedzą specjalistyczną. Należy zwrócić uwagę na aktualne informacje producenta pojazdu dotyczące przebudowy i wyposażenia dodatkowego. Demontaż i montaż należy przeprowadzać zgodnie z aktualnymi informacjami dotyczącymi naprawy. Należy upewnić się, czy pojazd znajduje się w stanie technicznym, który umożliwi założenie sprzęgu przyczepowego. Należy czytywać buforową pamięć błędów i w razie potrzeby aktualizować oprogramowanie. W przypadku problemów ograniczyć wyszukiwanie błędów do ok. 0,5 godziny, skontaktować się z linią serwisową ✉ ekitsupport@erich-jaeger.de / ☎ 01805 537289</p>
<p>TR</p>	<p>Bilgi:</p> <p>Montajdan önce aşağıdaki uyarılara dikkat edilmelidir: Montaj talimatının tamamıyla okunması gerekmektedir. Montaj sadece ilgili uzman bilgilerine sahip uzman personel tarafından yapılmalıdır. Araç üreticisinin yeniden donatma ve sonradan donatmayla ilgili aktüel uyarılara dikkat edilmesi gerekmektedir. Sökme ve monte etme adımlarının güncel tamir kılavuzlarına göre yapılması gerekmektedir. Araçın teknik olarak çekme kancasının işletilmesi için uygun olmasının sağlanması gerekmektedir. Araçın arıza hafızası okunmalı ve gerekiyorsa yazılım güncellenmelidir. Fonksiyon problemlerinde hata araması yakl. 0,5 saat ile sınırlanmalıdır, E-Satz Helpline ile iletişime geçilmelidir. ✉ ekitsupport@erich-jaeger.de / ☎ 01805 537289</p>
<p>H</p>	<p>Utalás:</p> <p>A szerelés megkezdése előtt a következő útmutatásokat kell figyelembe venni: Teljesen el kell olvasni a beszerelési útmutatót. A beszerelést csak megfelelő szakismeretekkel rendelkező szakembernek szabad végeznie. Figyelembe kell venni a járműgyártó át- és utólagos beszerelésre vonatkozó aktuális útmutatásait és információit. A ki- és beszerelési lépéseket az aktuális javítási kézikönyvek alapján kell végrehajtani. Biztosítani kell, hogy a jármű műszaki szempontból alkalmas legyen vonóhorog használatára. Ki kell olvasni a jármű hibamemóriáját, és szükség esetén frissíteni kell a szoftvert. Funkcionális problémák esetén a hibakeresés kb. 0,5 órára korlátozandó, vegye fel a kapcsolatot az E-Satz segélyvonallal ✉ ekitsupport@erich-jaeger.de / ☎ 01805 537289</p>
<p>HR</p>	<p>Uputa:</p> <p>Prije početka montaže valja uzeti u obzir sljedeće naputke: U cijelosti je potrebno pročitati upute za ugradnju. Ugradnju bi trebalo provoditi samo stručno osoblje s odgovarajućim poznavanjem struke. Ono se mora pridržavati aktualnih naputaka i informacija proizvođača vozila o preinaci i dodatnom opremanju. Koraci vađenja i ugradnje moraju se provesti na osnovi aktualnih smjernica za popravljjanje. Mora se osigurati da vozilo tehnički bude prikladno za rad spojke prikolice. Mora se očitati memorija grešaka vozila i po potrebi aktualizirati softver. Kod funkcijskih problema traženje grešaka mora se ograničiti na otprilike 0,5 sati, kontaktirajte telefonsku liniju za pomoć u vezi elektronskih setova E-Satz ✉ ekitsupport@erich-jaeger.de / ☎ 01805 537289</p>
<p>BUL</p>	<p>Указание:</p> <p>Преди началото на монтажа е необходимо да се съблюдават следните указания: Упътването за монтаж трябва да се прочете изцяло. Монтажът трябва да се извърши само от специализиран персонал със съответните специализирани познания. Трябва да се съблюдават актуалните указания и информация на производителя на превозното средство за преоборудвания и следоборудвания. Стъпките по разглобяване и сглобяване следва да се извършват с помощта на актуалните ръководства за ремонт. Трябва да е установено, че превозното средство е технически подходящо за експлоатация на теглич за ремарке. Паметта за грешки на автомобила трябва да се разчете и при необходимост софтуерът да се актуализира. При функционални проблеми търсенето на грешки трябва да се ограничи до около 0,5 часа, свържете се с телефонната линия за помощ във връзка с електронни мрежи E-Satz ✉ ekitsupport@erich-jaeger.de / ☎ 01805 537289</p>
<p>RO</p>	<p>Indicație:</p> <p>Înainte de a începe montajul se vor avea în vedere următoarele: Instrucțiunile de montaj trebuie citite integral. Se recomandă ca montajul să fie executat numai de către personal calificat cu cunoștințe de specialitate. Instrucțiunile și recomandările actuale ale producătorului autovehiculului privoare la modificări și completări ale dotării trebuie respectate. Operațiunile de demontare respectiv montare trebuie efectuate în conformitate cu îndreptările de reparații actuale. Trebuie clarificat dacă vehiculul este adecvat pentru utilizarea unui cuplaj de remorcare. Citiți memoria de erori a autovehiculului și actualizați software-ul, dacă este necesar. În caz de probleme funcționale limitați căutarea defectiunilor la aprox. 0,5 ore și adresați-vă serviciului de suport prin telefon E-Satz ✉ ekitsupport@erich-jaeger.de / ☎ 01805 537289</p>

<p>(RU)</p>	<p>Указание:</p> <p>Перед началом установки необходимо учесть следующие указания:</p> <p>Полностью прочитайте руководство по установке. Установка должна проводиться только специально обученным персоналом, имеющим соответствующие знания Необходимо учитывать актуальные указания и информацию по переоснащению и дооборудованию завода-изготовителя транспортного средства. Все действия по демонтажу и монтажу необходимо проводить руководствуясь указаниями по ремонту. Необходимо убедиться в том, что транспортное средство технически подходит для установки тягово-сцепного устройства. Необходимо учитывать память неисправностей автомобиля и при необходимости обновить программное обеспечение. При проблемах в работе поиск неисправностей следует ограничить прикл. до 0,5 часа, свяжитесь со службой поддержки по комплектam электрических деталей ✉ ekitsupport@erich-jaeger.de / ☎ 01805 537289</p>
<p>(LT)</p>	<p>Nuoroda:</p> <p>Prieš pradedant įmontavimą turi būti laikomasi šių nurodymų:</p> <p>Turi būti perskaityta visa įmontavimo instrukcija. Įmontavimas turi būti atliktas tik kvalifikuoto personalo su atitinkamomis kvalifikacinėmis žiniomis. Turi būti laikomasi aktualių transporto priemonės gamintojų nurodymų bei informacijos, skirtų pertvarkymui ir derinimui. Išmontavimo ir įmontavimo darbai turi būti atliekami pagal aktualų remonto vadovą. Nustatyti, kad transporto priemonė techniniu atžvilgiu tinkama eksploatuoti su sukabinamuoju įtaisu. Reikia nuskaityti transporto priemonės klaidų atmintį ir prireikus atnaujinti programinę įrangą. Jei yra funkcinų trikdžių, klaidų paiešką reikia sutrumpinti iki 0,5 valandos. Susisiekite elektroninių rinkinių pagalbos linija ✉ ekitsupport@erich-jaeger.de / ☎ 01805 537289</p>
<p>(LV)</p>	<p>Norādījums:</p> <p>Pirms montāžas sākuma jāievēro sekojoši noteikumi:</p> <p>Pilnībā jāizlasa montāžas instrukcija. Montāžu drīkst veikt tikai šim nolūkam apmācīts speciālists. Jāievēro aktuālos transportlīdzekļa ražotāja norādījumus un informāciju par pārbūvi un aprikošanu. Demontāžas un montāžas pasākumi jāveic saskaņā ar aktuālajiem norādījumiem par remontēšanu. Jāpārliedzinās, ka transportlīdzeklis ir tehniski piemērots lietošanai ar piekabes saījūgu. Jānolasa transportlīdzekļa kļūdu atmiņa un, ja nepieciešams, jāatjaunina programmatūra. Darbības traucējumu gadījumā kļūdu meklēšana jāierobežo uz apm. 0,5 stundām. Lūdzu, sazinieties ar E-komplekta palīdzības dienestu ✉ ekitsupport@erich-jaeger.de / ☎ 01805 537289</p>
<p>(EST)</p>	<p>Juhis:</p> <p>Enne montaaži alustamist tuleb järgida järgmisi juhiseid:</p> <p>Lugeda täielikult läbi paigaldusjuhend. Paigaldamise peaks teostama üksnes vastavate erialaste oskustega personal. Tuleb järgida sõiduki tootja ajakohaseid juhiseid ja ajakohast infot ümberehituste ja tagantjärele muudatuste tegemise kohta. Lahti- ja kokkupanek tuleb teostada ajakohaste remondijuhiste kohaselt. Tuleb veenduda, et sõiduk sobib tehniliselt haakeseadmega töötamiseks. Lugeda sõiduki vigade mälu ja vajadusel värskendada tarkvara. Talitusprobleemide korral tuleb veaotsingu piiriliseks ajaks võtta ligikaudu 0,5 tundi, pöörduda E-Satz Helpline poole ✉ ekitsupport@erich-jaeger.de / ☎ 01805 537289</p>
<p>(SLO)</p>	<p>Navodilo:</p> <p>Pred začetkom montaže morate upoštevati naslednja navodila:</p> <p>natančno preberite navodila za uporabo; montažo lahko izvaja samo strokovno osebje z ustreznim strokovnim znanjem; pred predelavami vozila in dodajanjem opreme morate upoštevati aktualna navodila in informacije proizvajalca vozila; Korake postopka demontaže in montaže morate izvesti s pomočjo aktualnih navodil za popravila. Zagotoviti morate, da je vozilo tehnično primerno za priklop priključka za prikolico; Pomnilnik napak vozila je treba odčitati in po potrebi je treba programsko opremo posodobiti. Pri težavah pri delovanju je treba iskanje napak omejiti na pribl. 0,5 ure in stopiti v stik z e-pomočjo ✉ ekitsupport@erich-jaeger.de / ☎ 01805 537289</p>
<p>(SK)</p>	<p>Pokyn:</p> <p>Pred začiatkom montáže treba dodržať nasledujúce upozornenia:</p> <p>Prečítajte si celý montážny návod. Montáž by mal vykonať iba odborný personál so zodpovedajúcimi odbornými znalosťami. Treba dodržiavať aktuálne upozornenia a informácie výrobcu vozidla týkajúce sa prestavby a dodatočného vybavenia. Jednotlivé kroky pri demontáži a montáži musia byť vykonané na základe aktuálnych návodov na opravy. Musí byť zaistené, že vozidlo je technicky vhodné na prevádzku s ťažným zariadením. Treba vyčítať obsah pamäte chýb vozidla a v prípade potreby treba aktualizovať softvér. Pri problémoch funkčnosti treba vyhľadávanie chýb obmedziť na cca 0,5 hodiny, kontaktujte Helpline E-Satz ✉ ekitsupport@erich-jaeger.de / ☎ 01805 537289</p>

KIT

737201

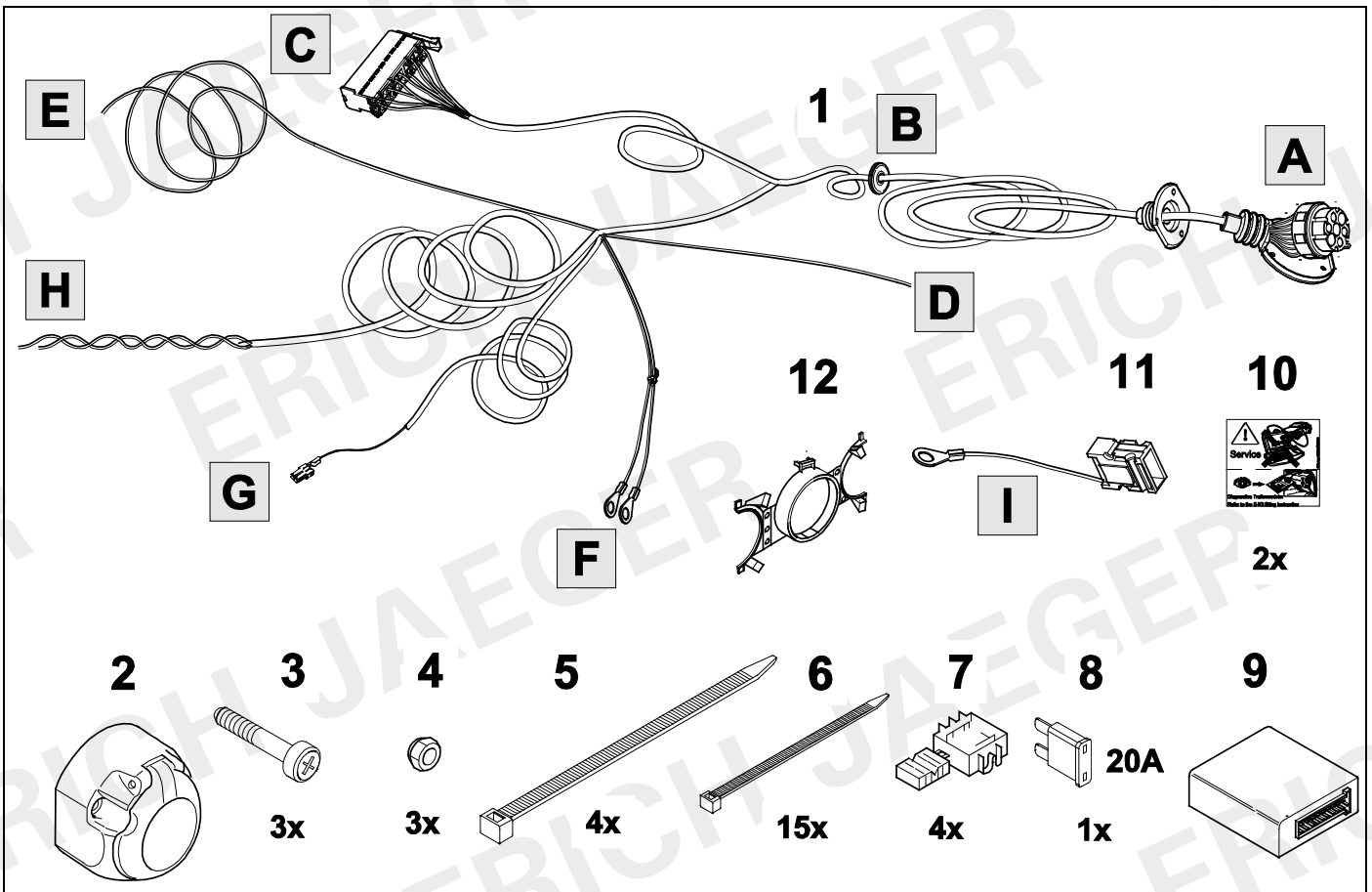

KIT

748401

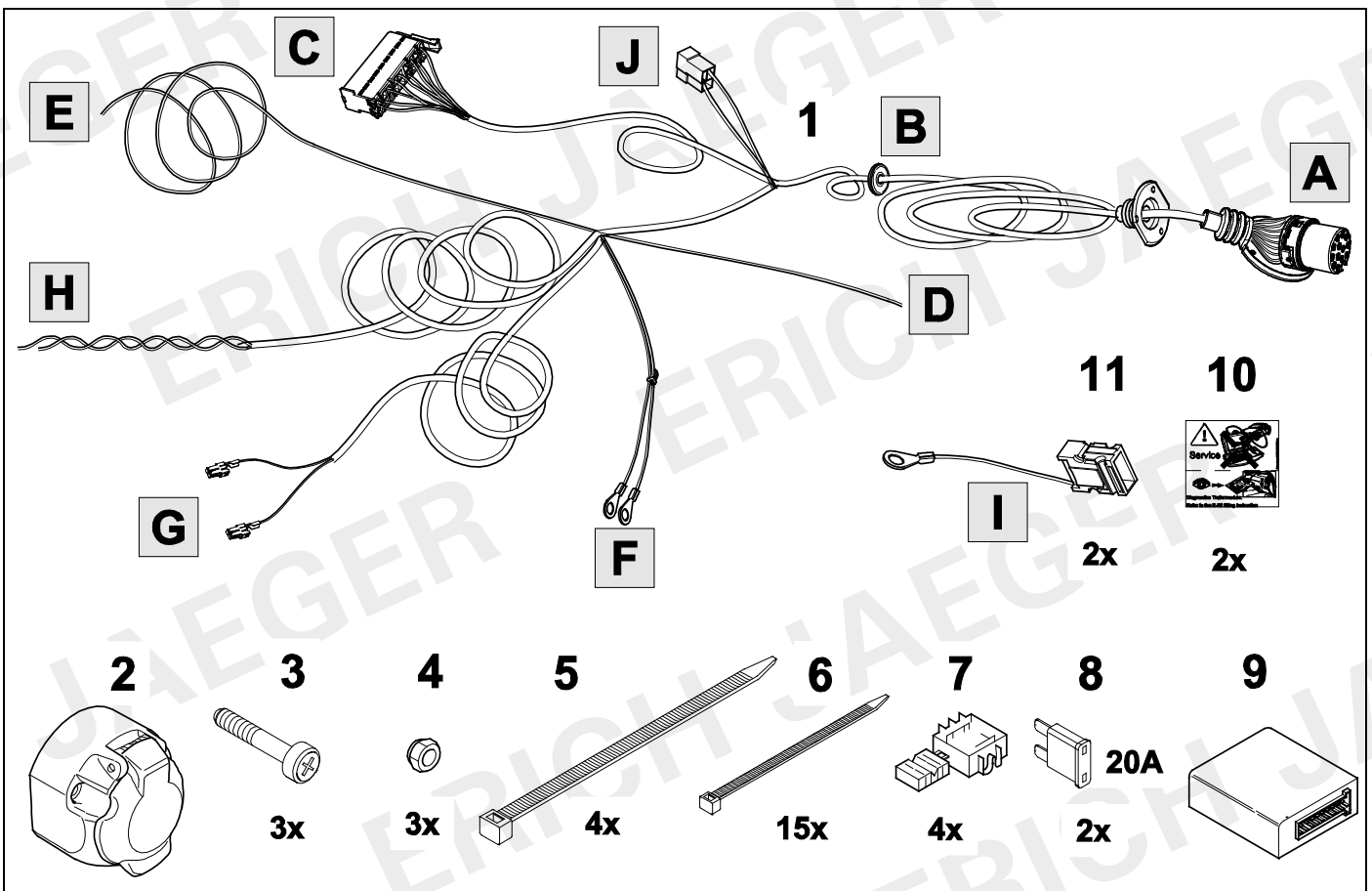

OVERVIEW

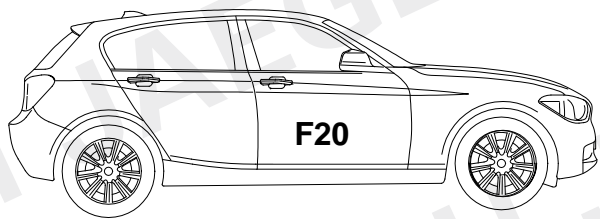

1

+

2

4

-

10

39

-

65

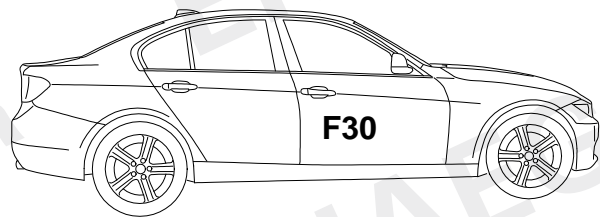

1

+

3

11

-

17

39

-

65

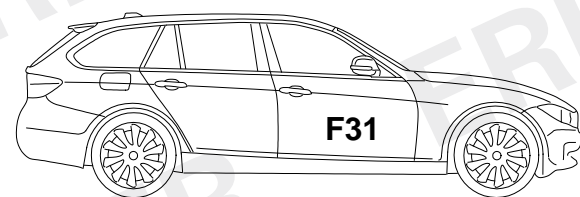

1

+

3

18

-

24

39

-

65

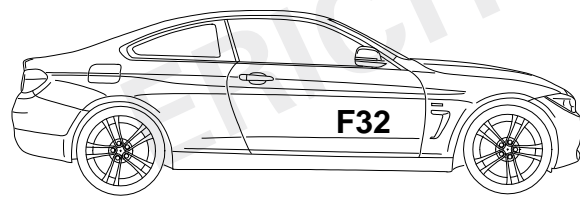

1

+

3

25

-

31

39

-

65

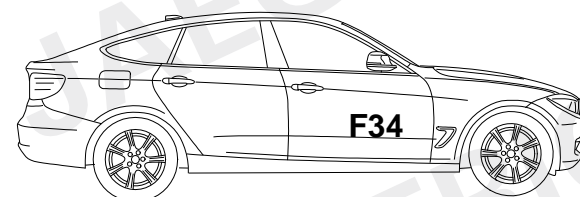

1

+

3

32

-

65

TOOLS

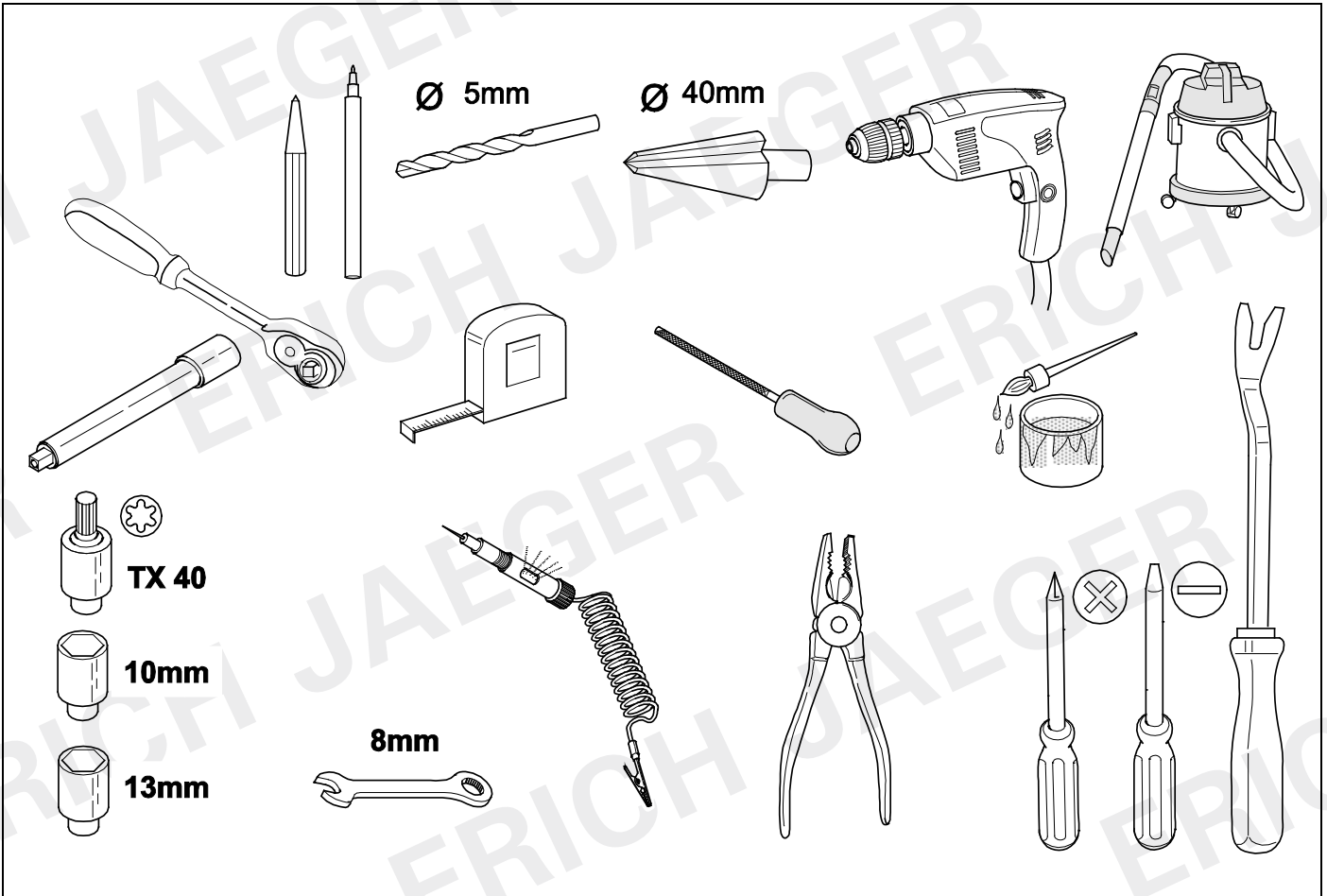

1

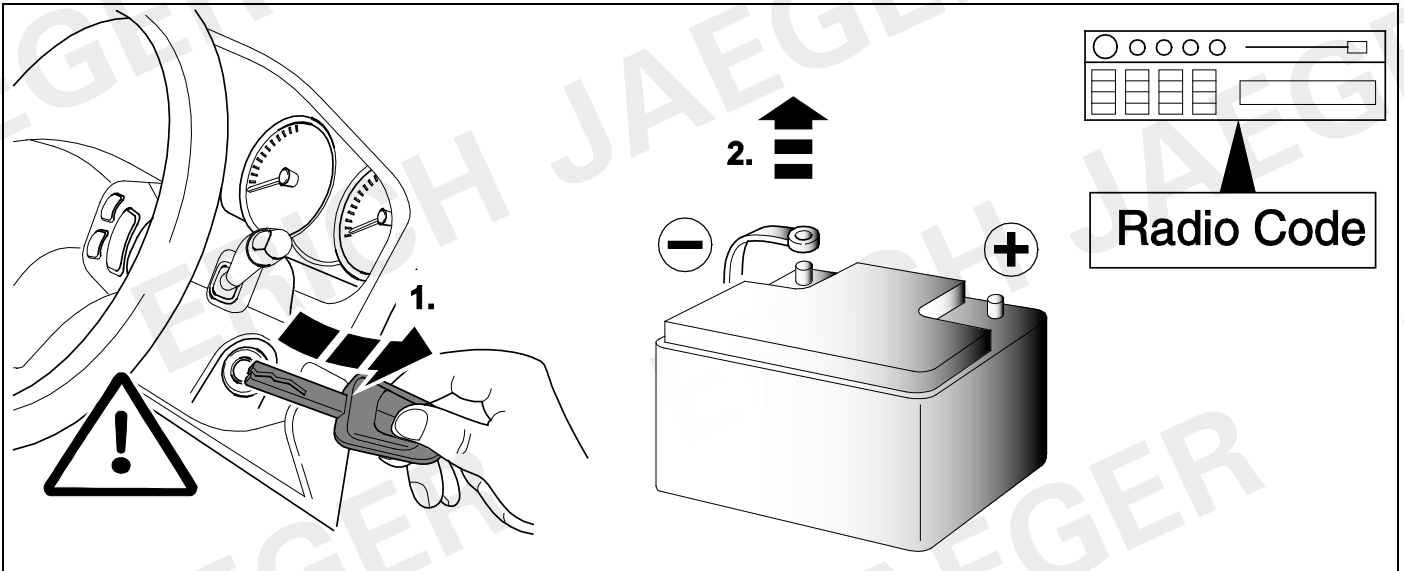

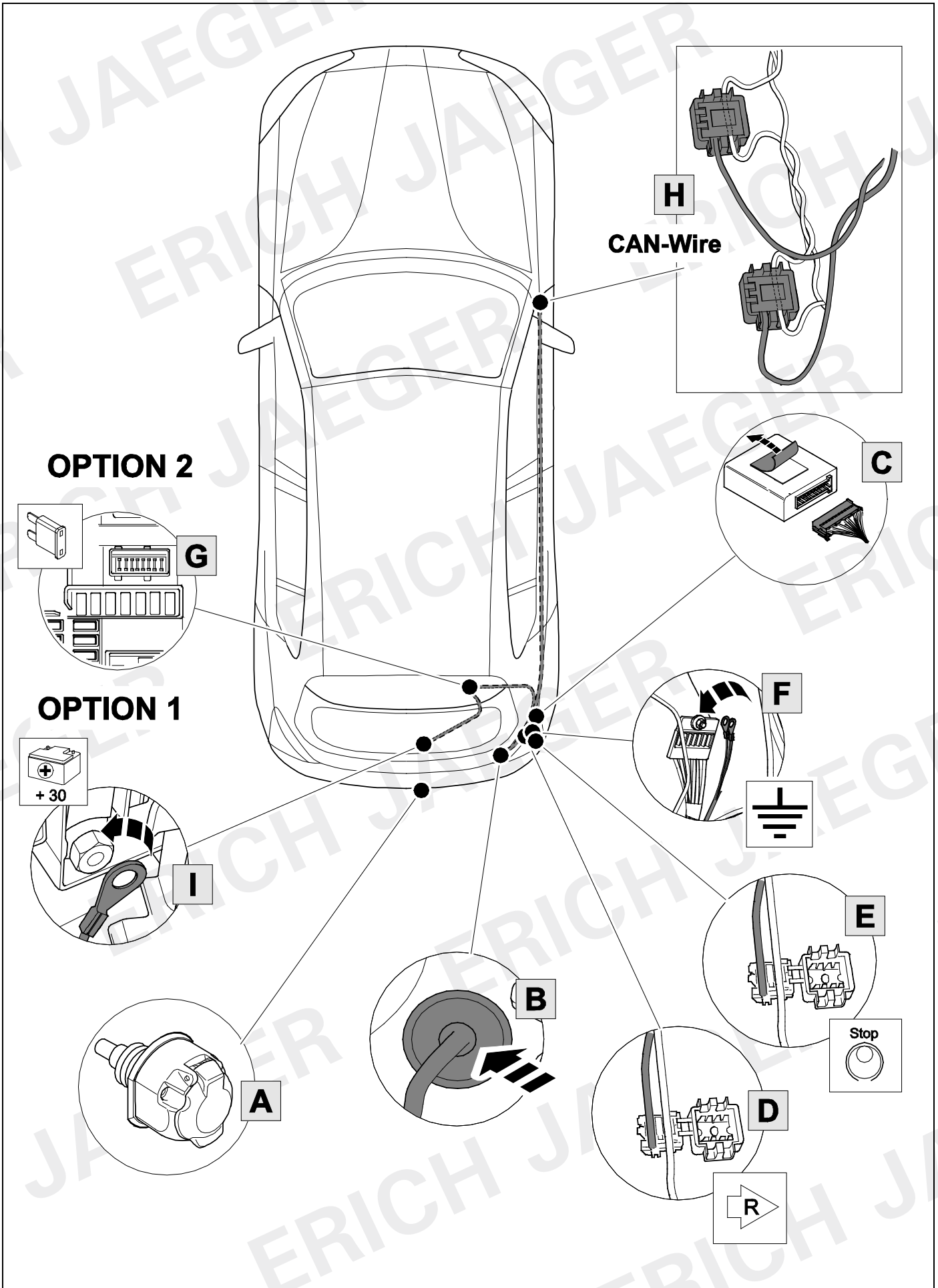

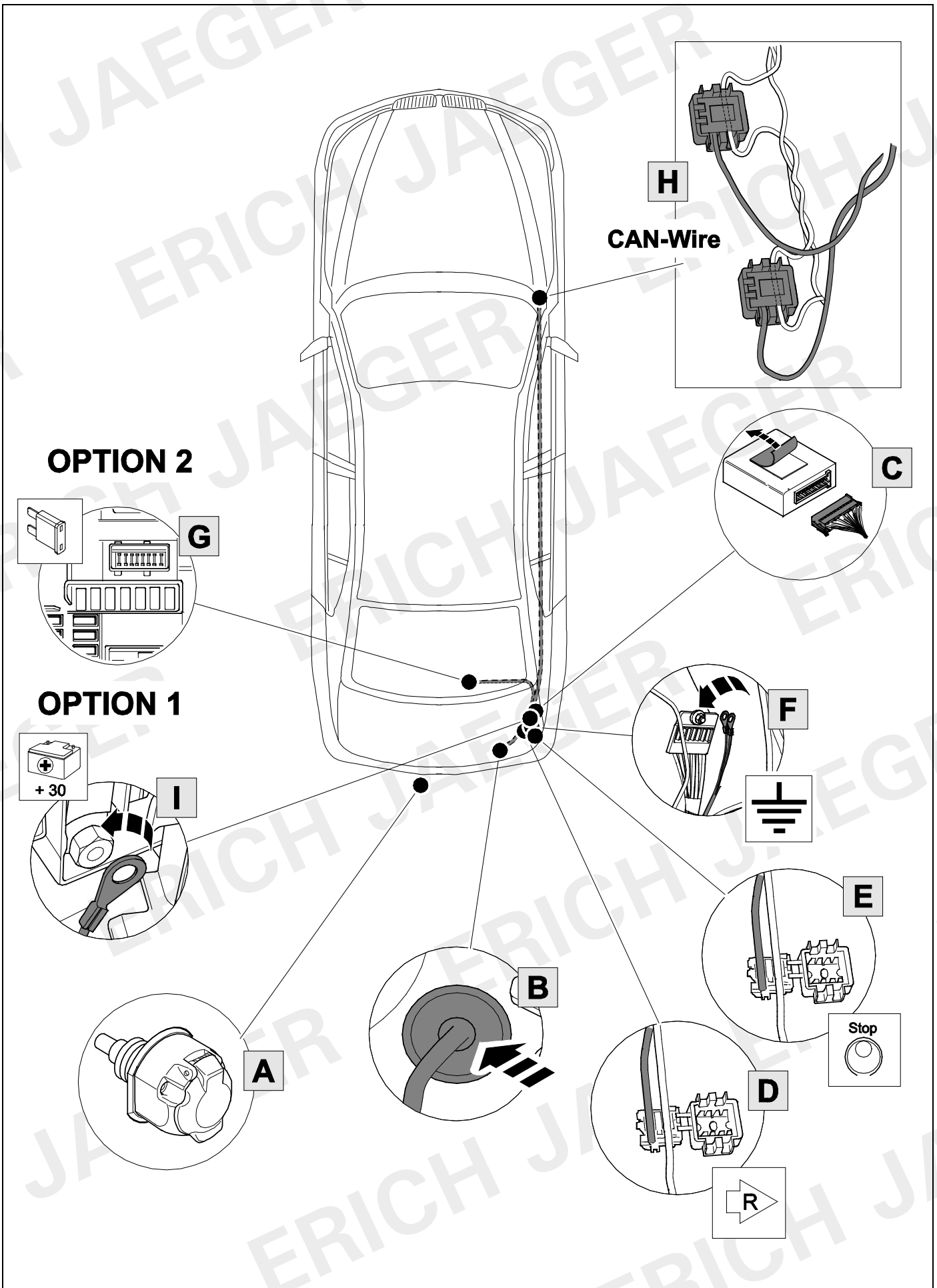

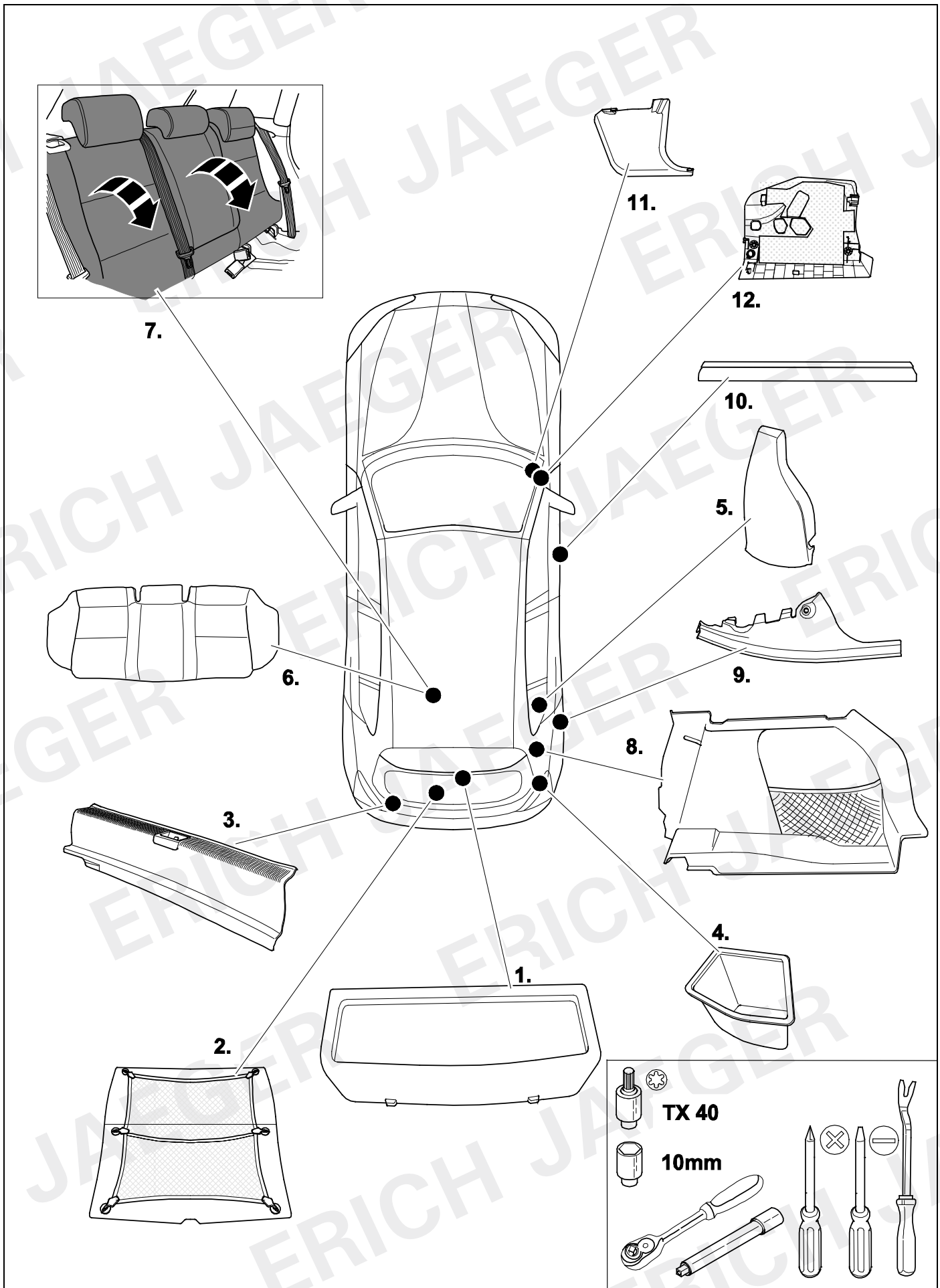

5

F20

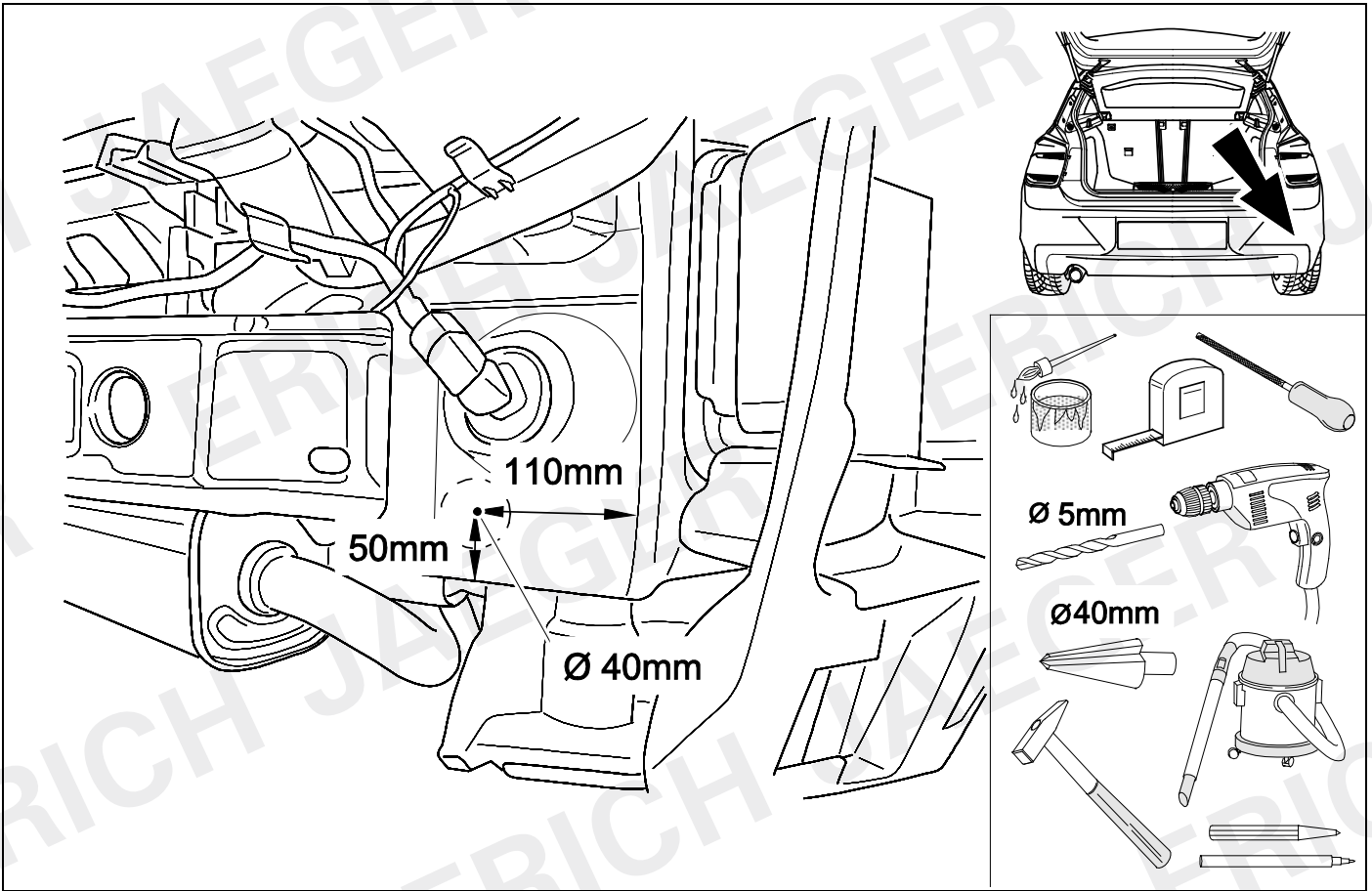

6

F20

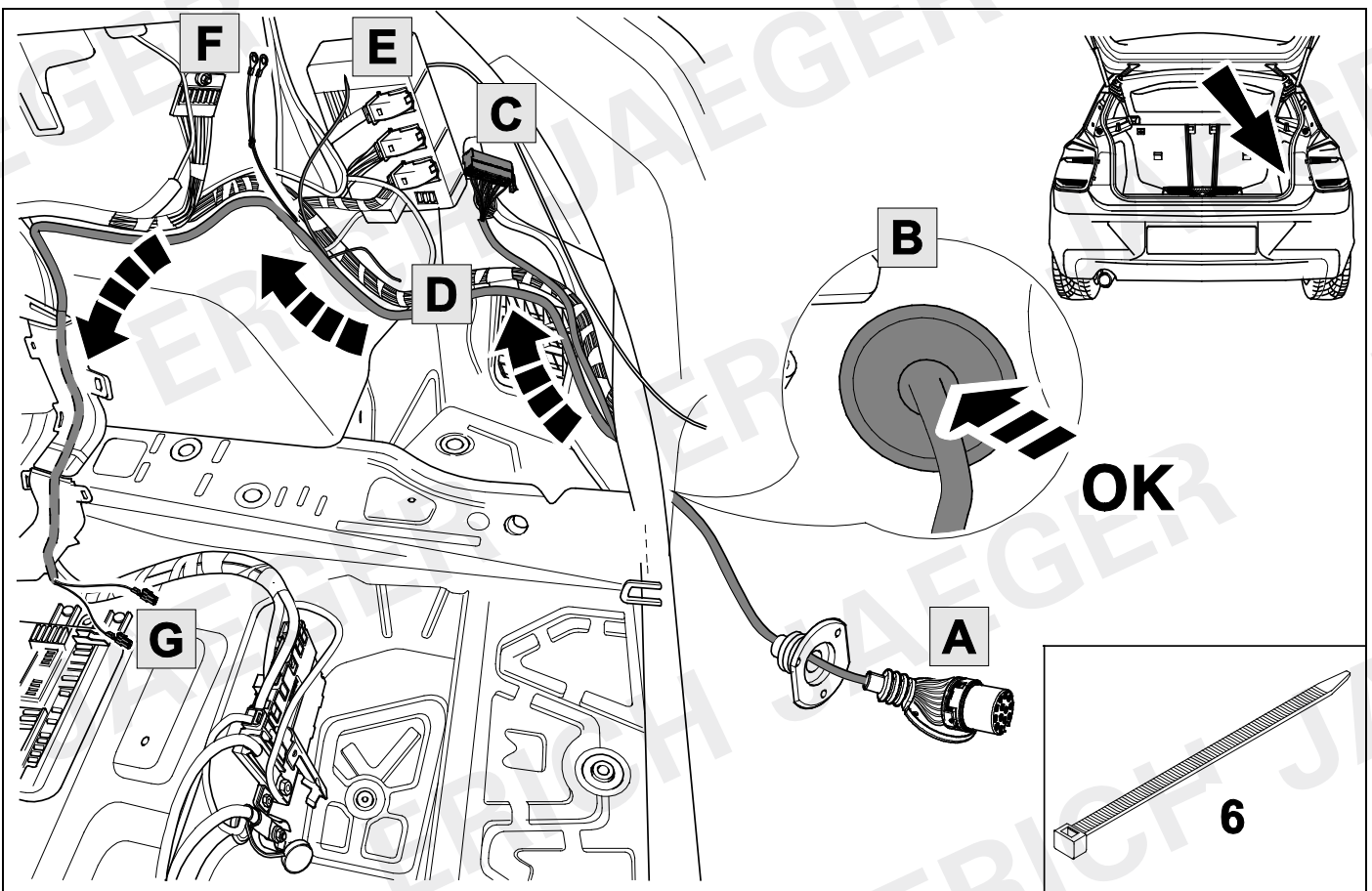

7

F20

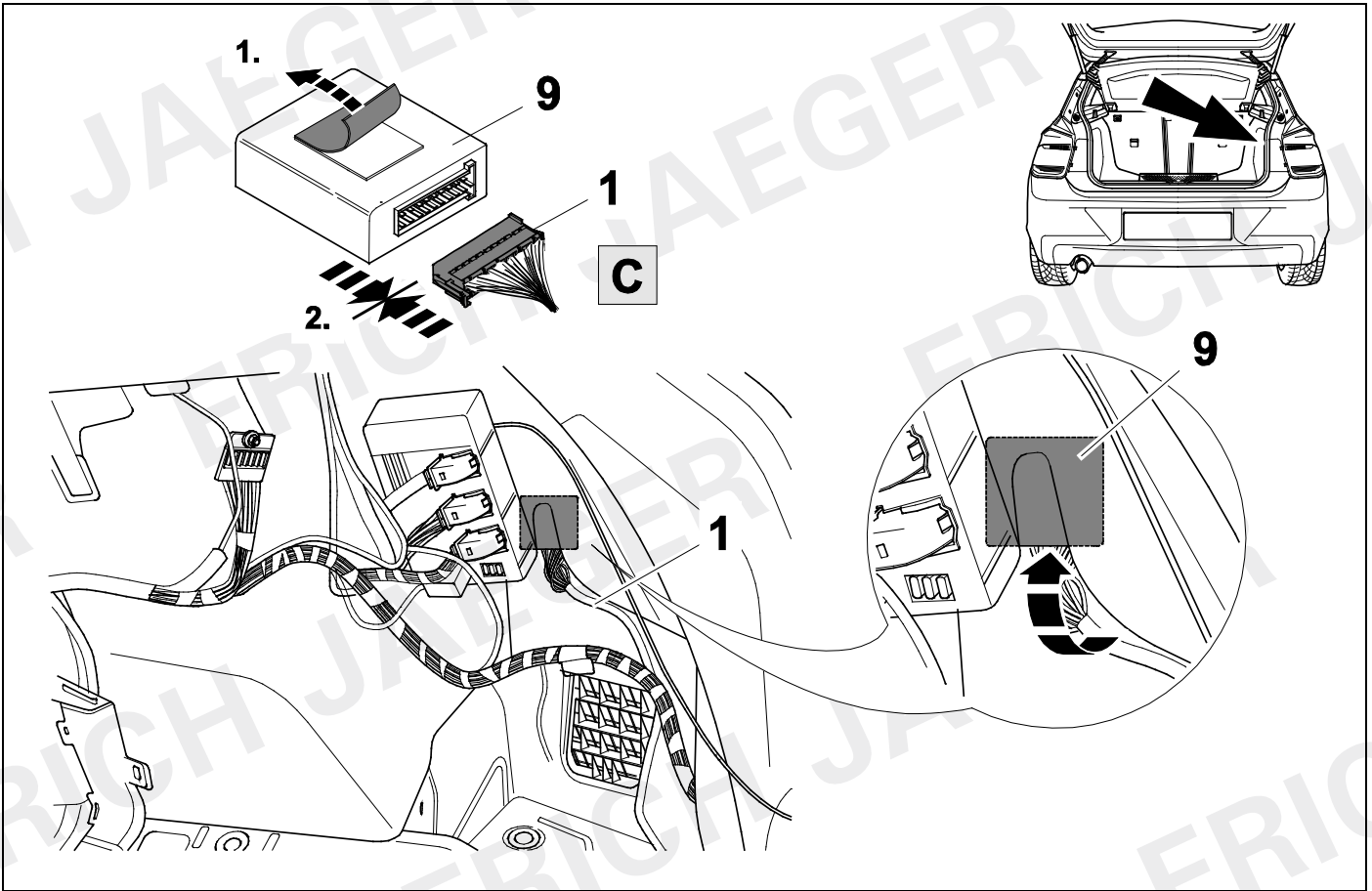

8



55

F20

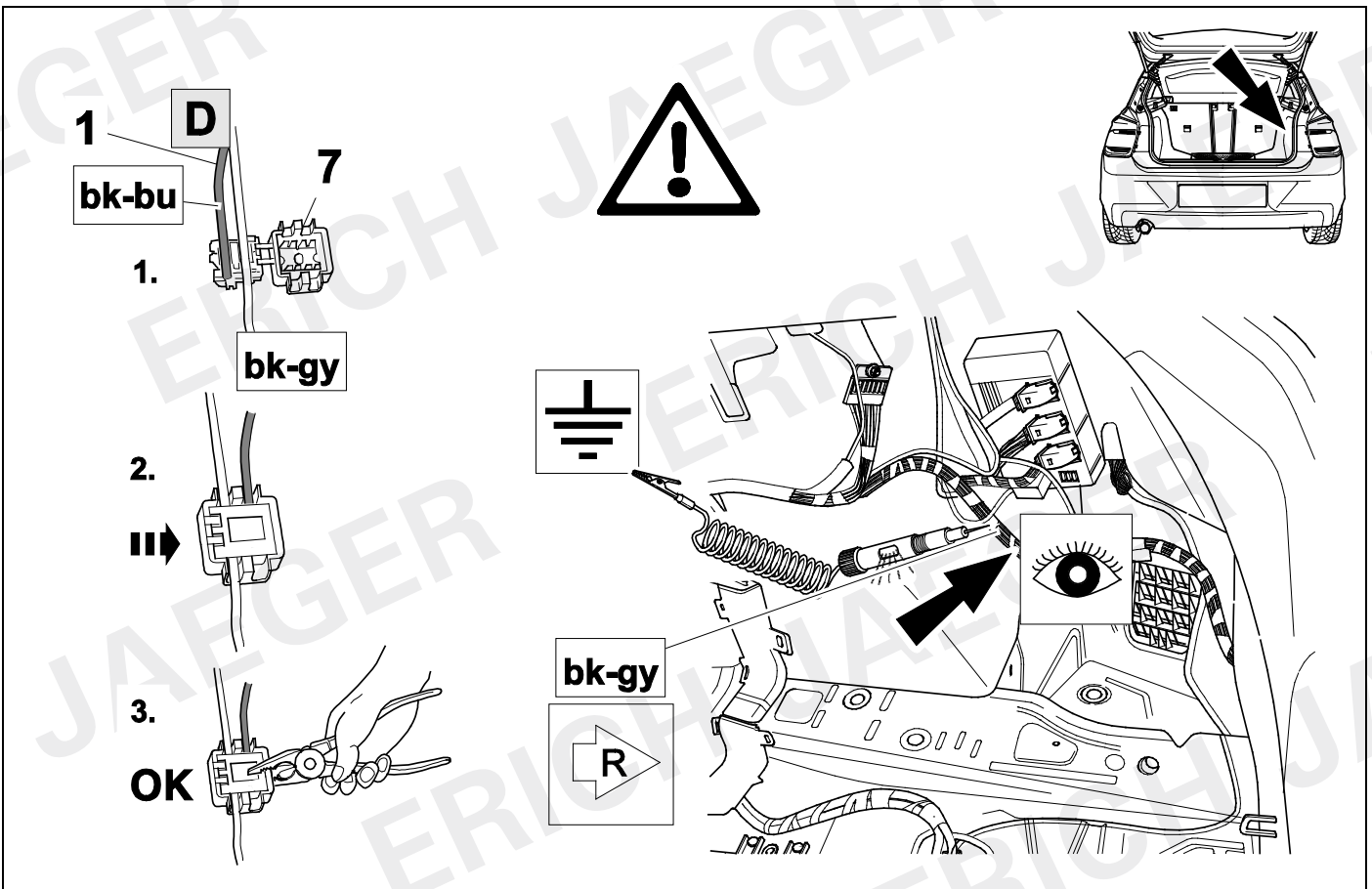

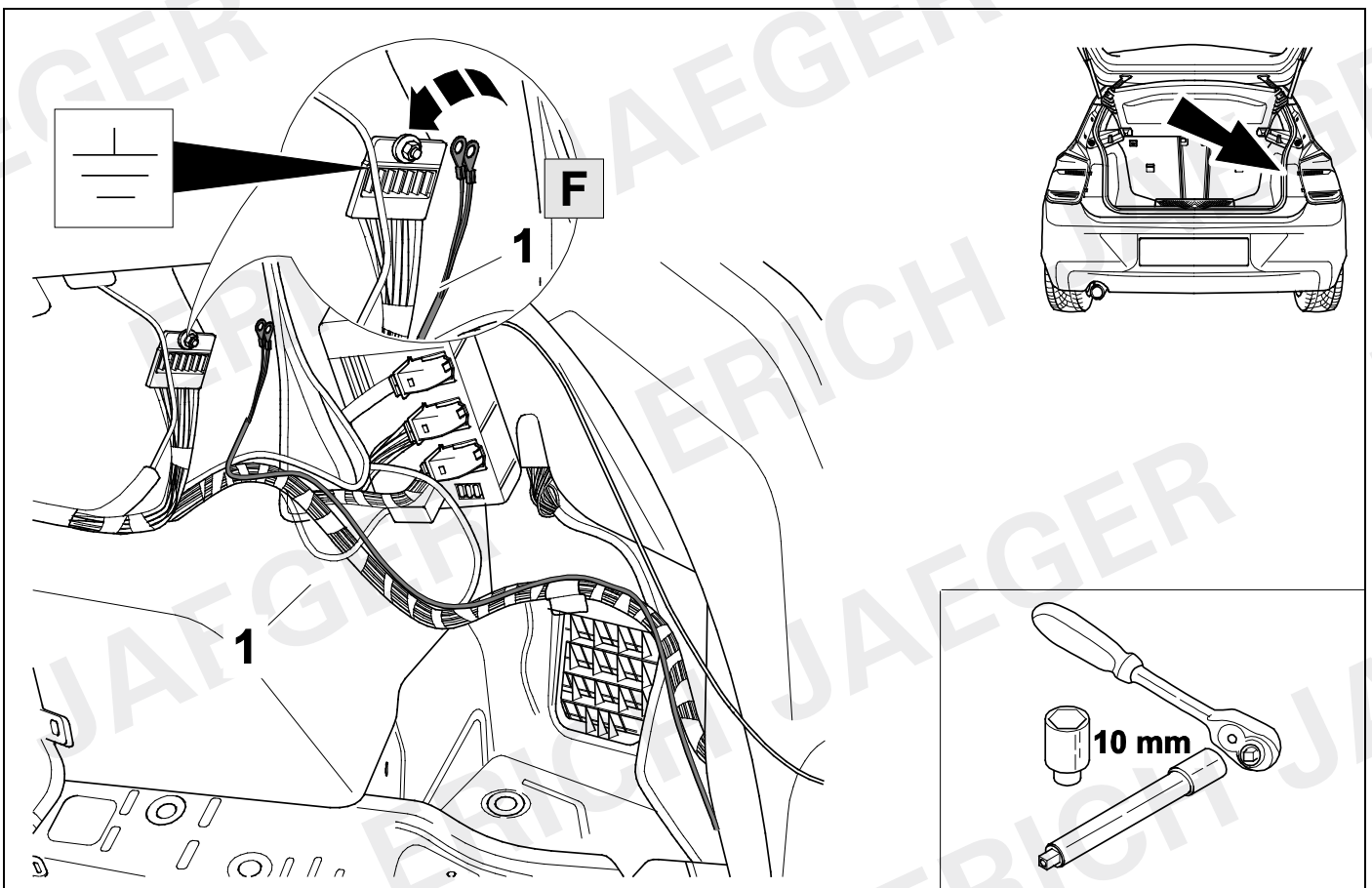
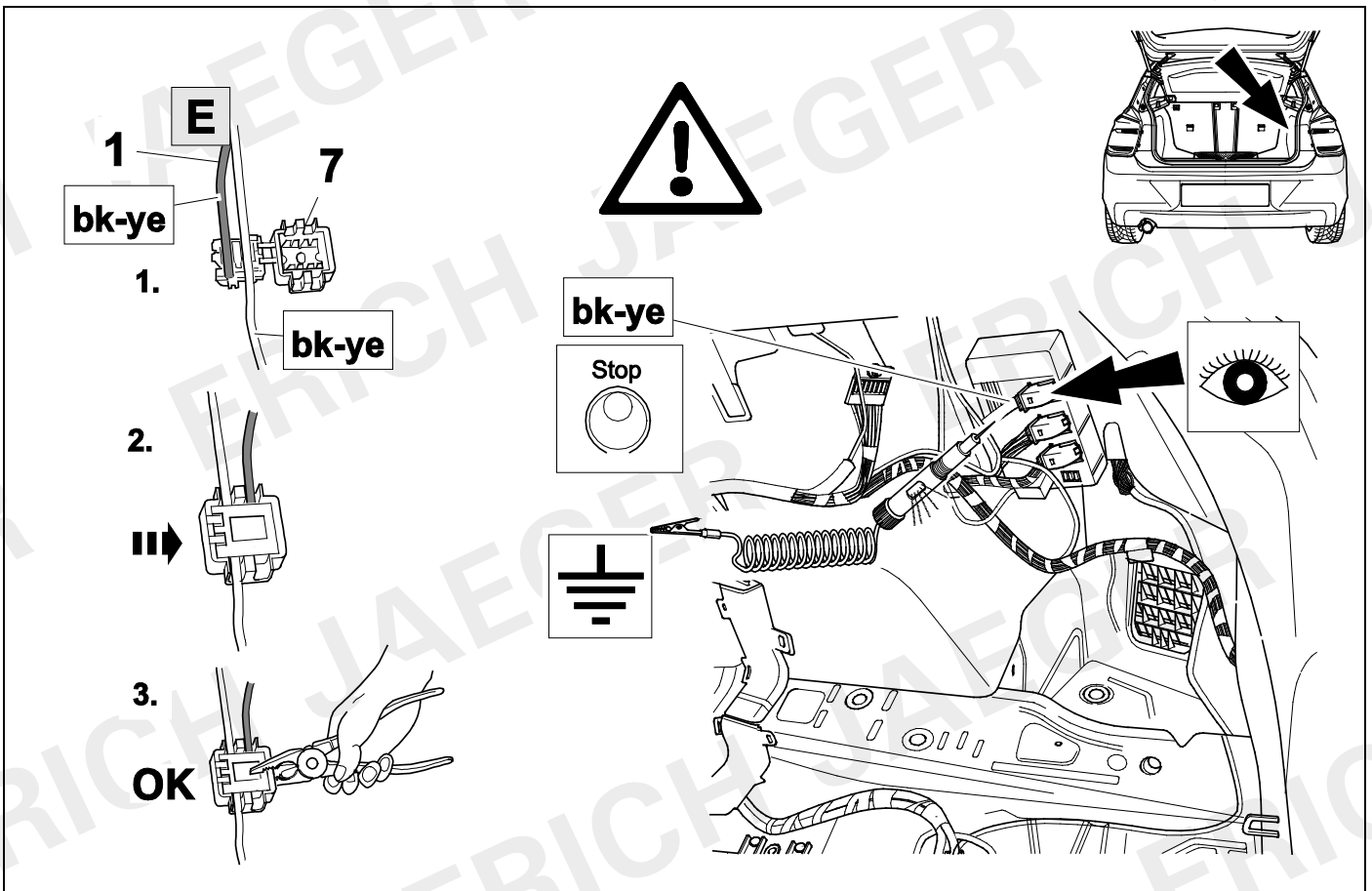

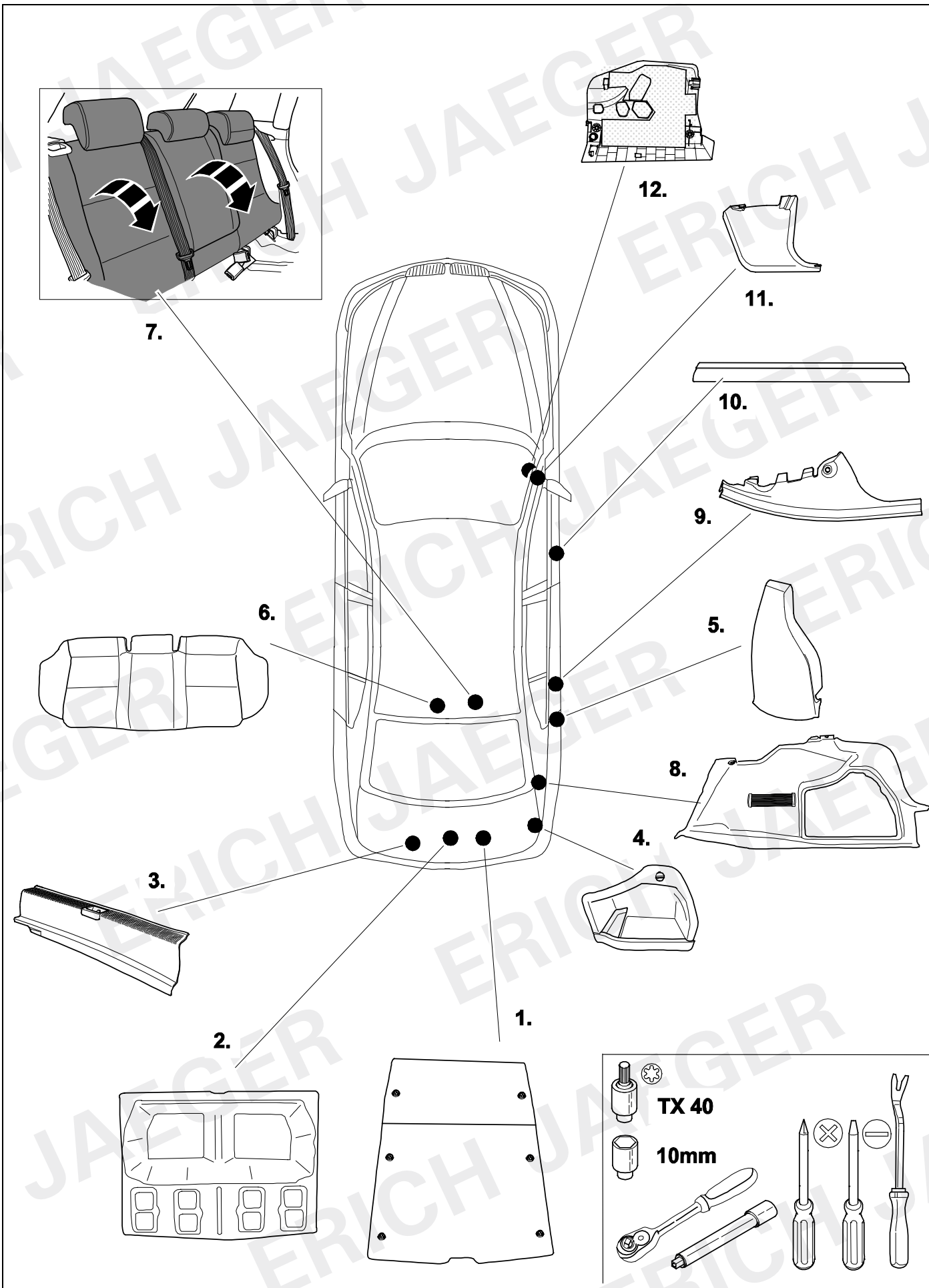

12

F30

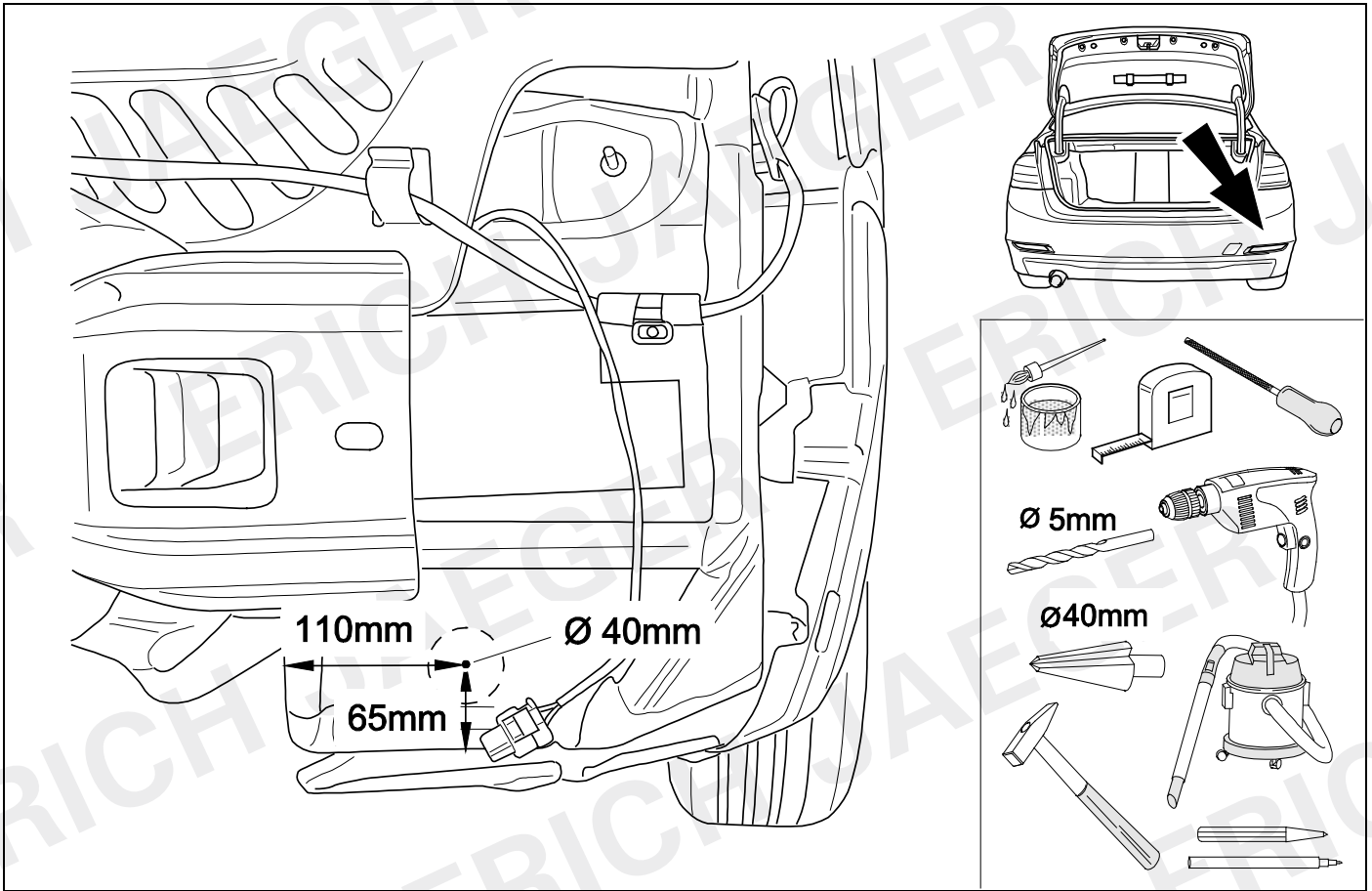

13

F30

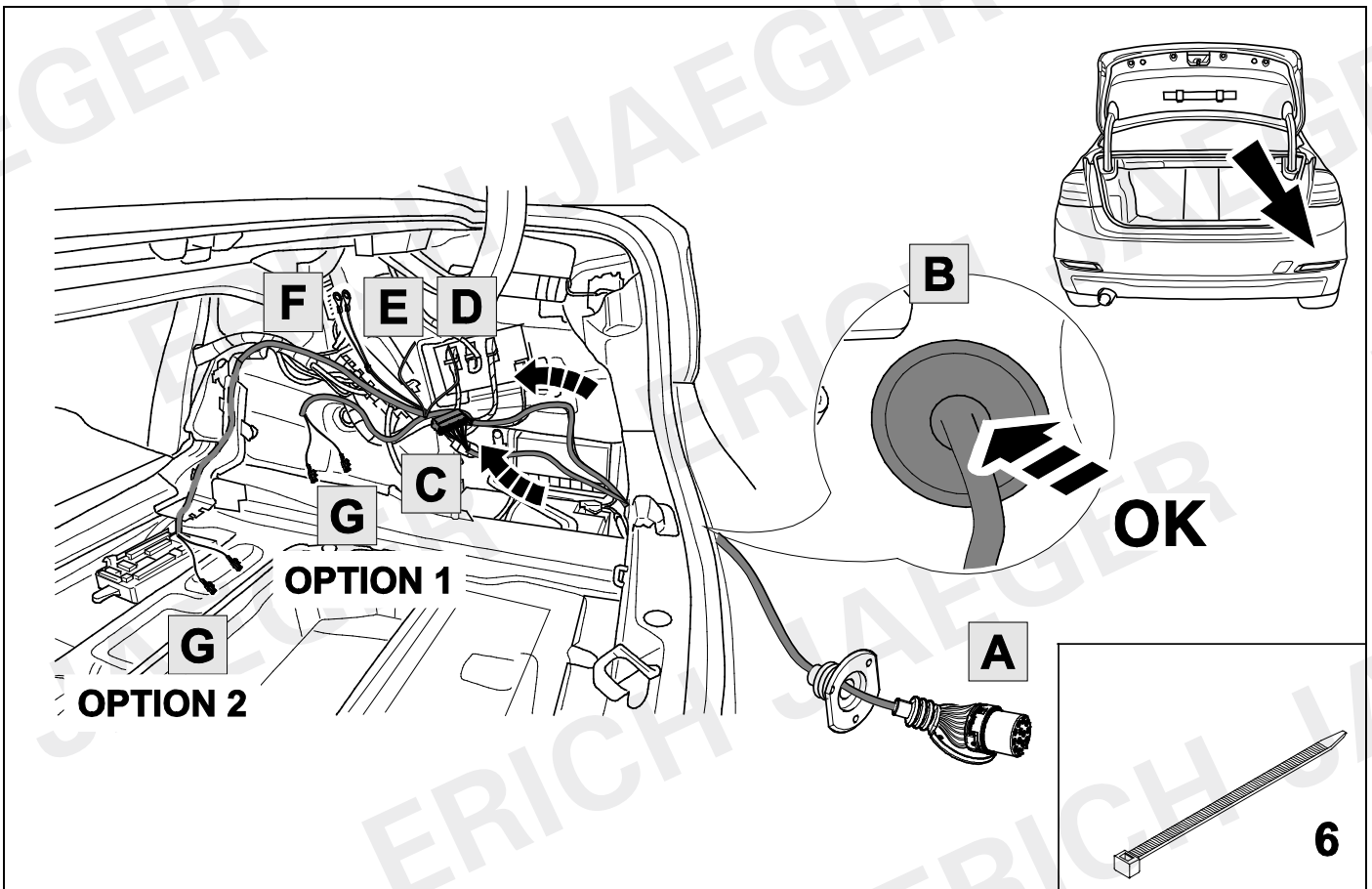

14

F30

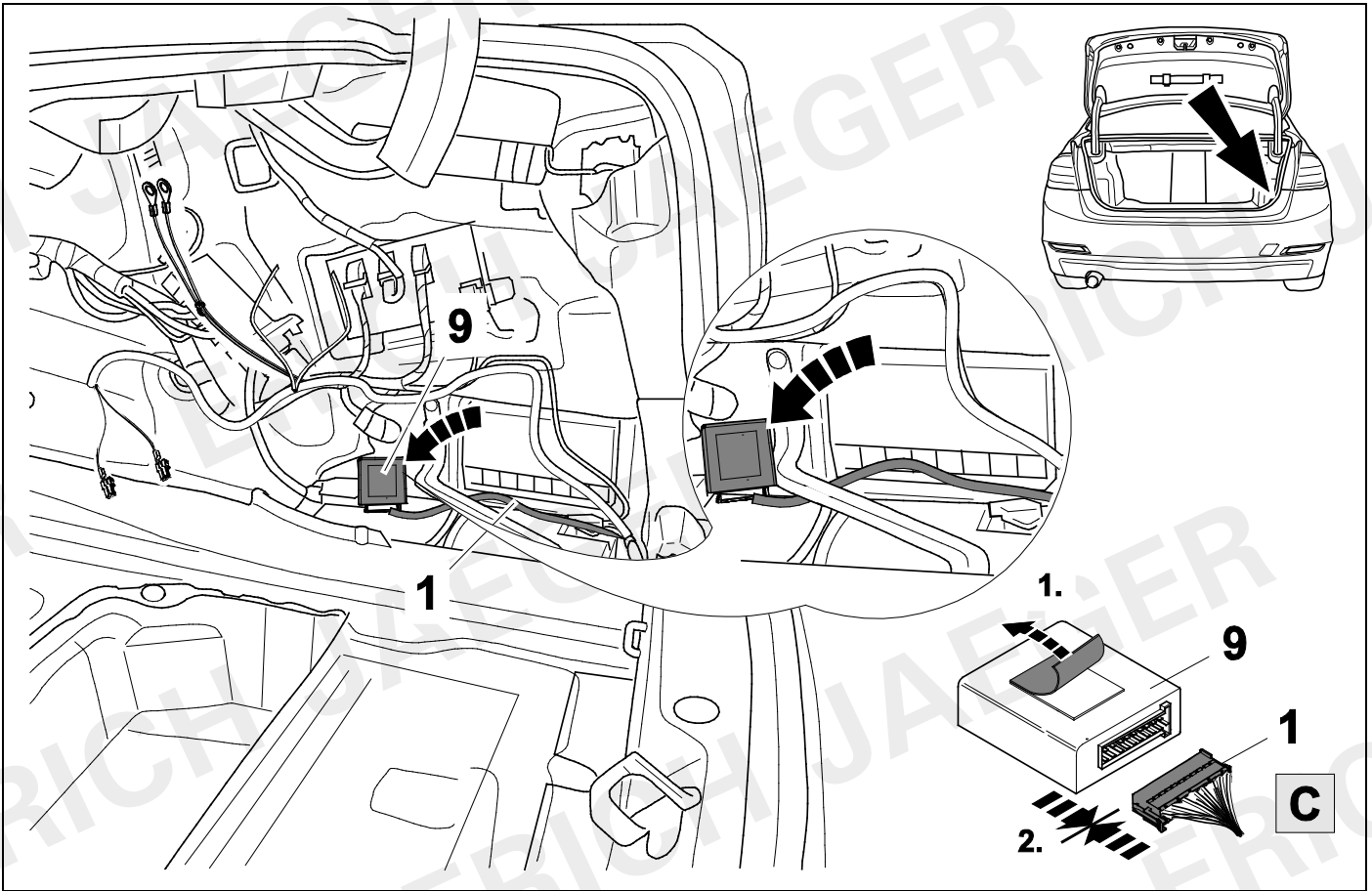

15



55

F30

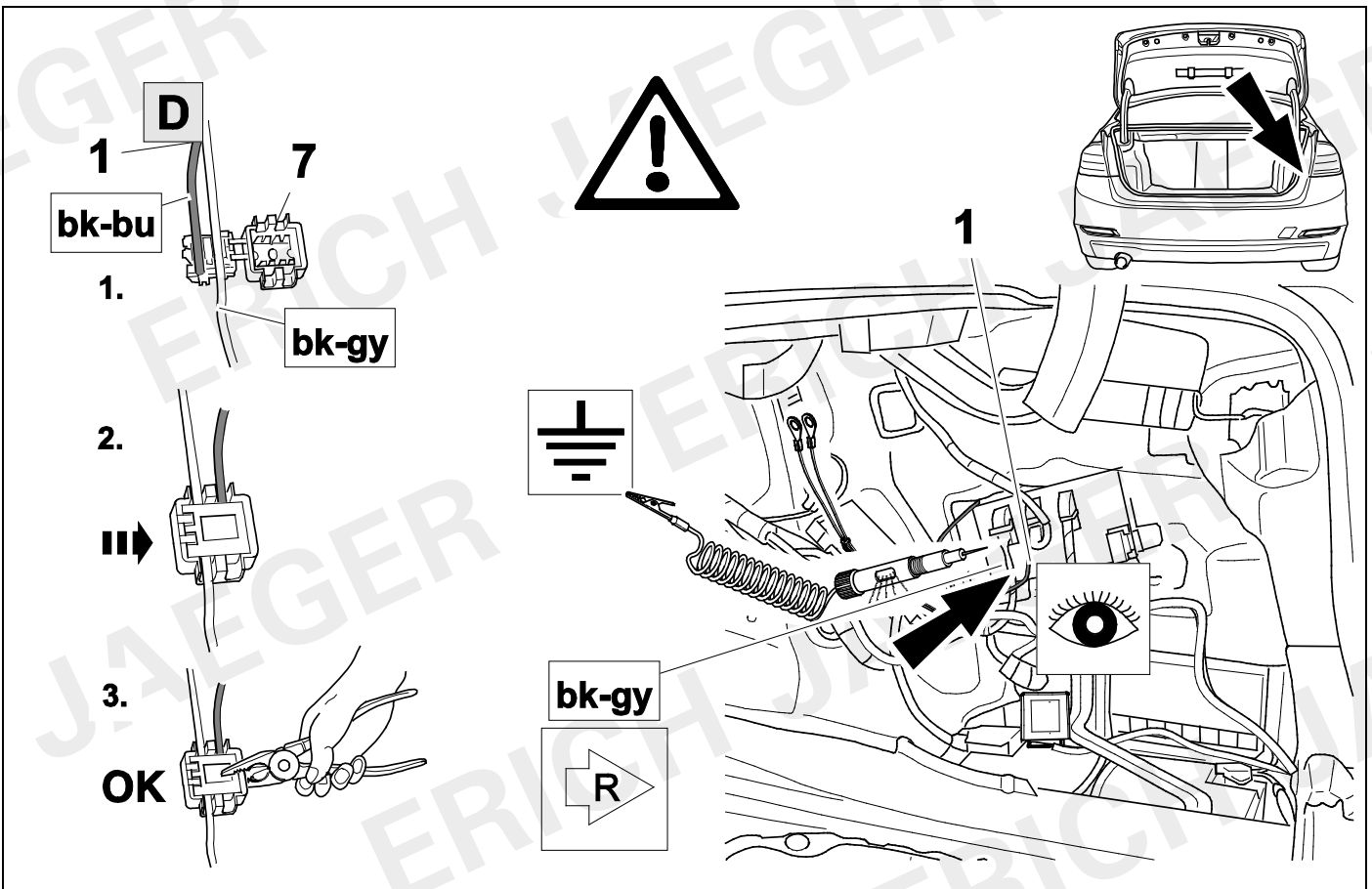

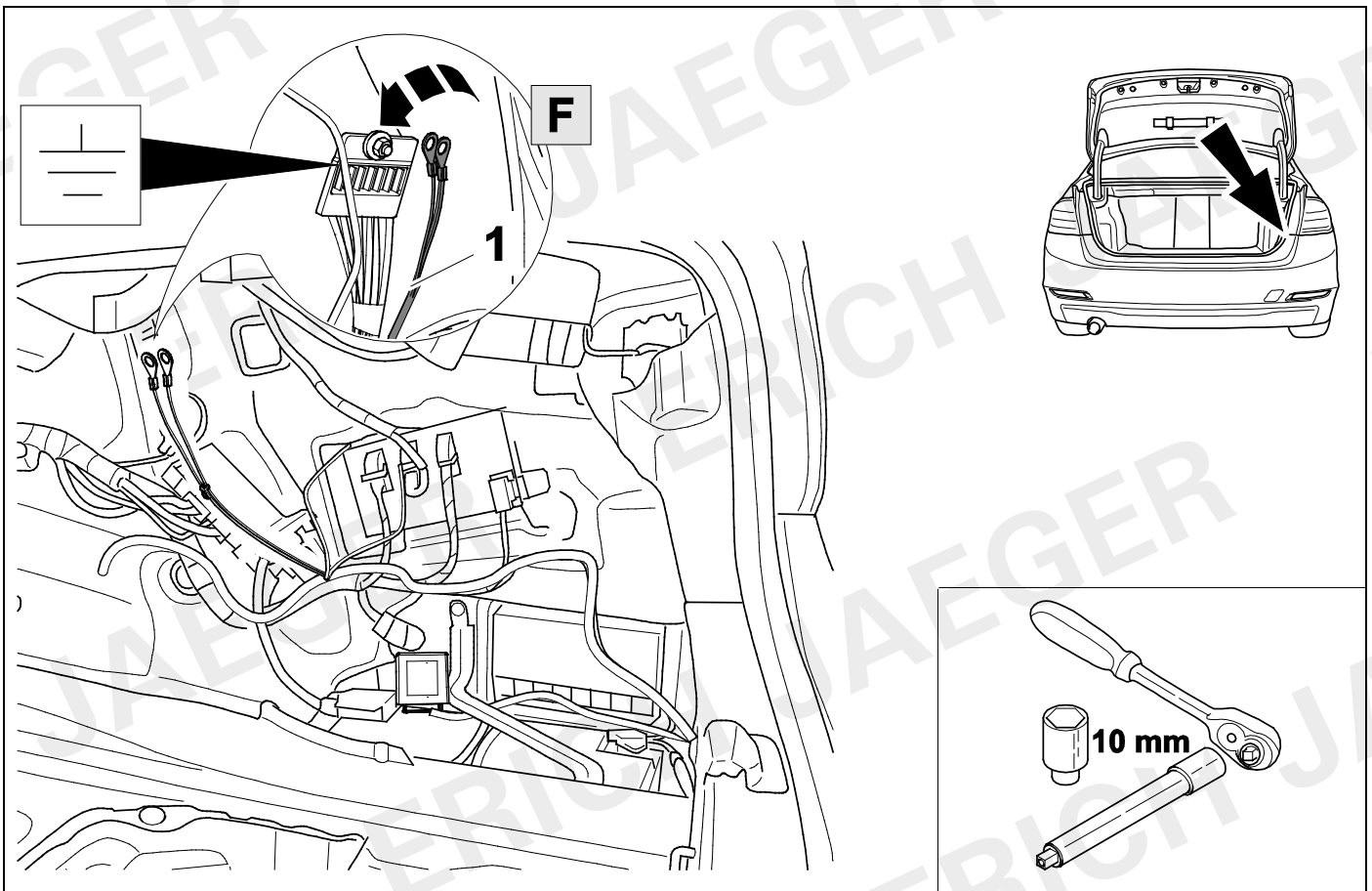
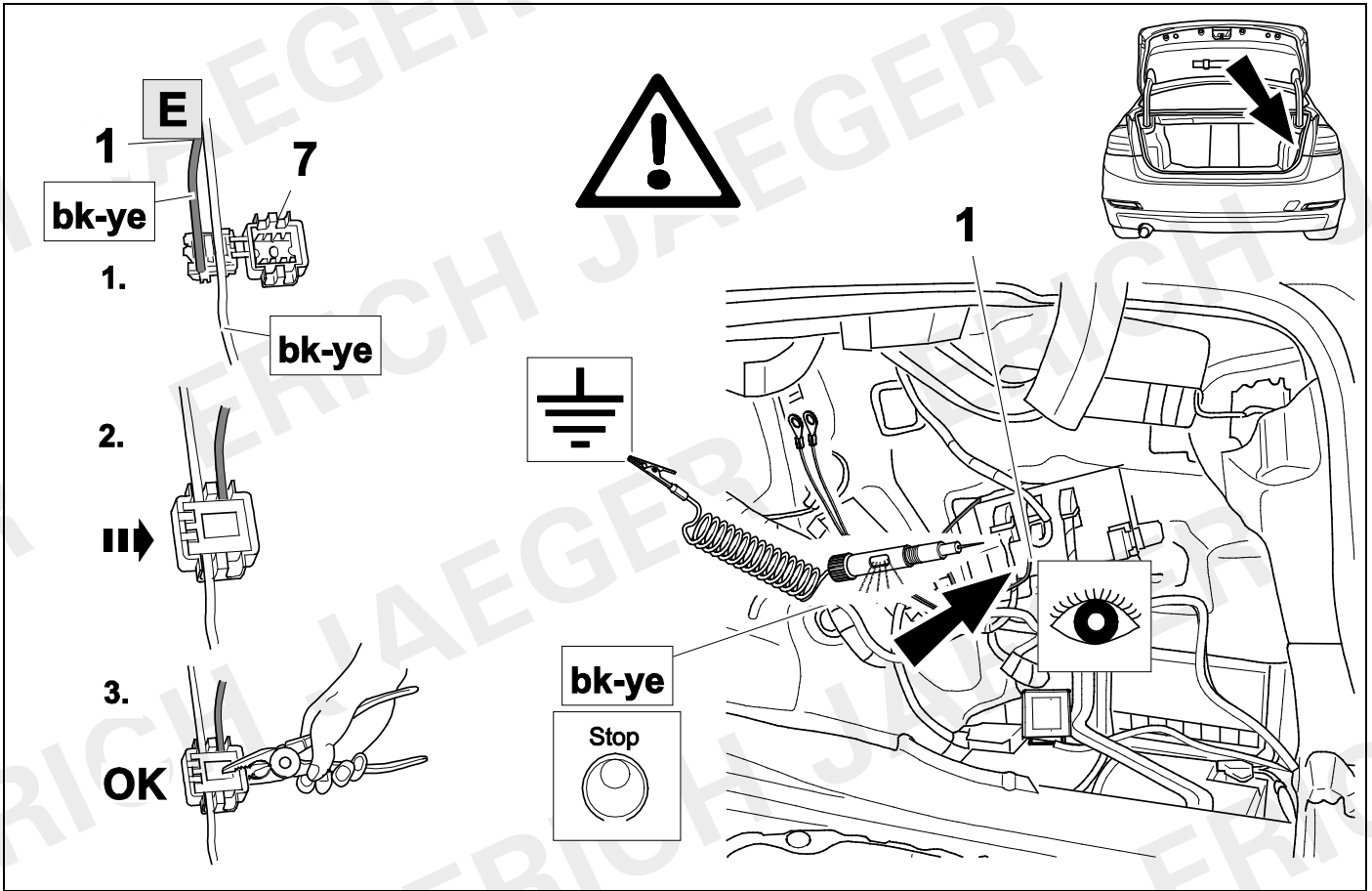

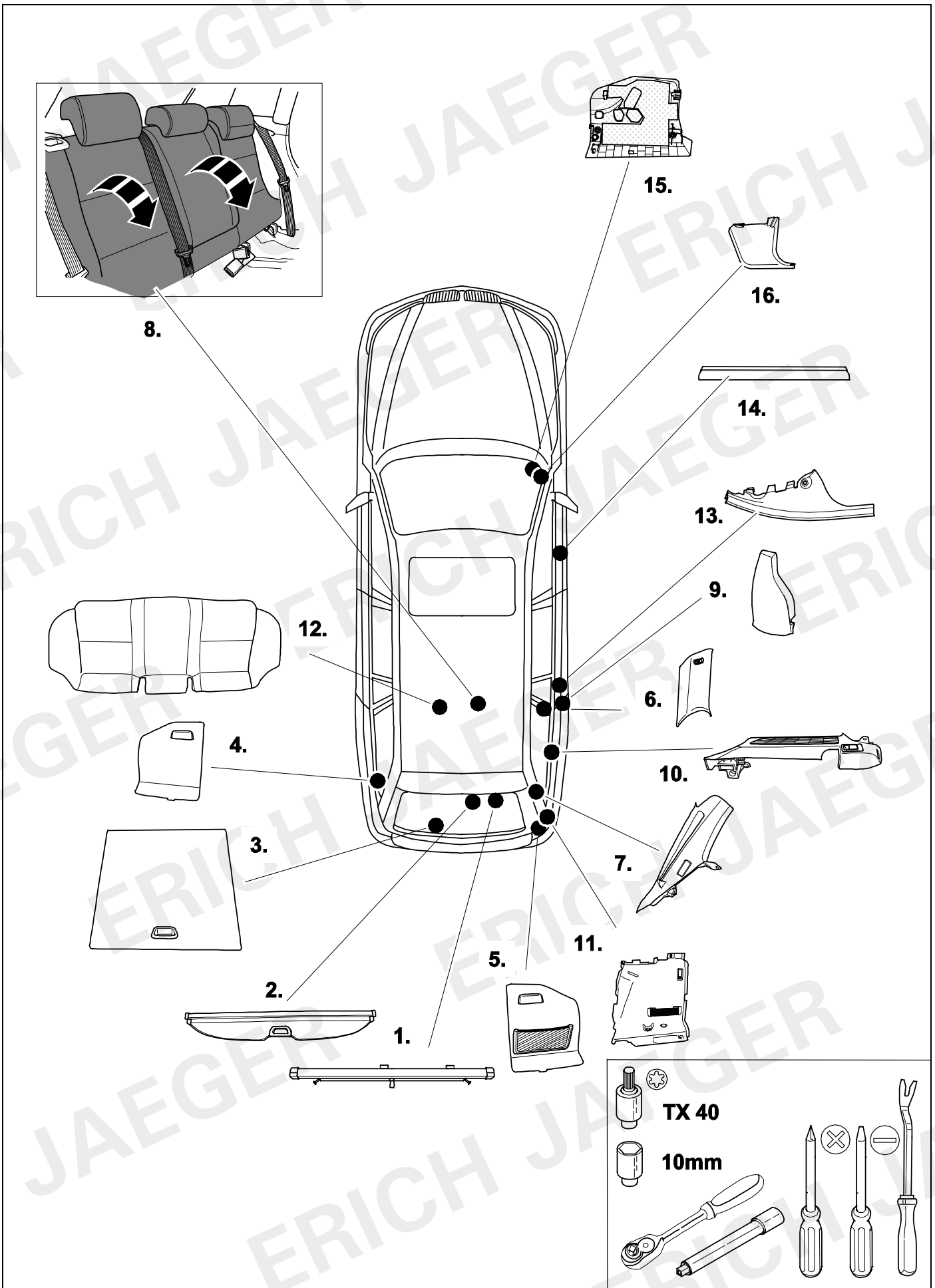

19

F31

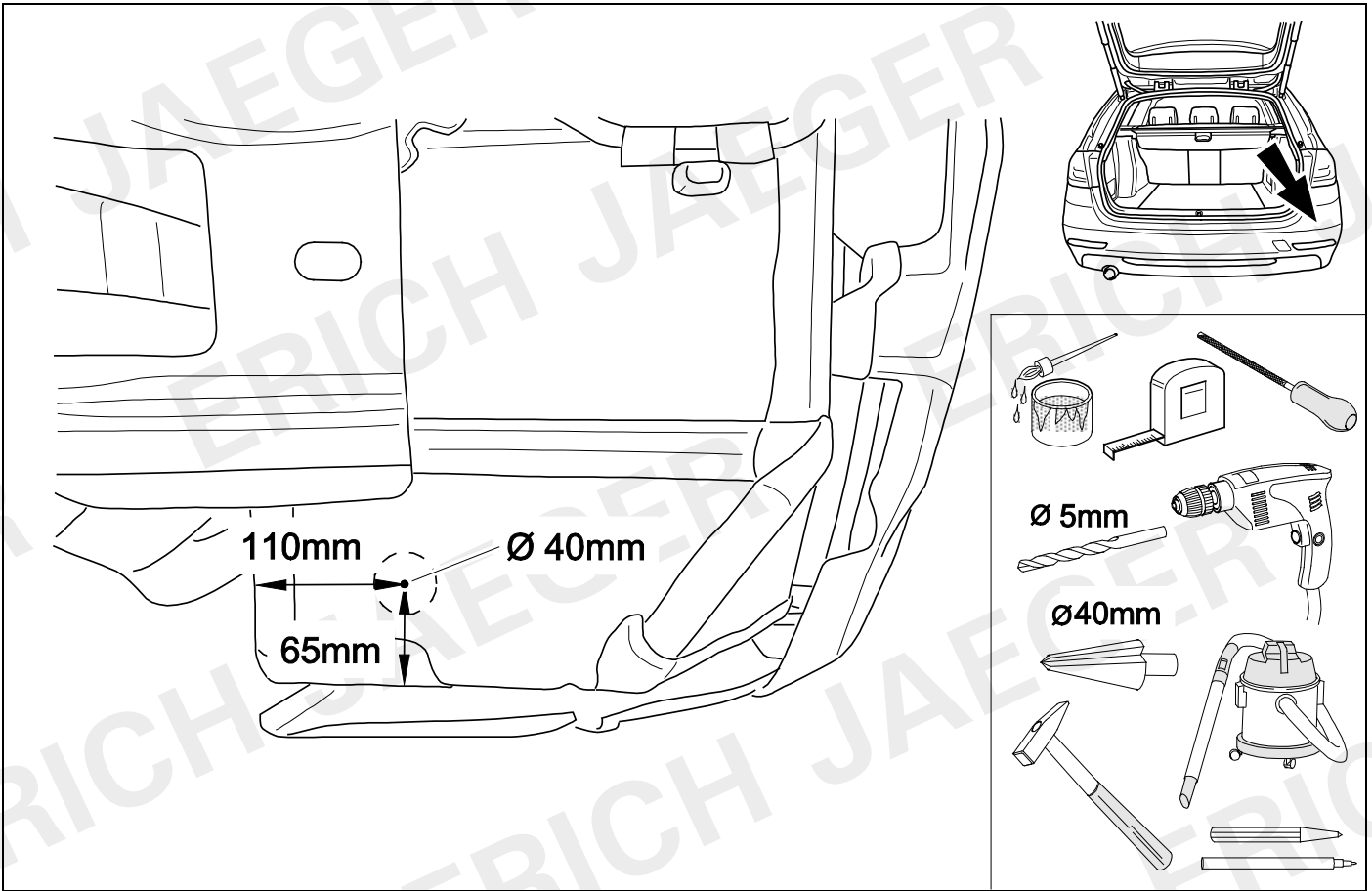

20

F31

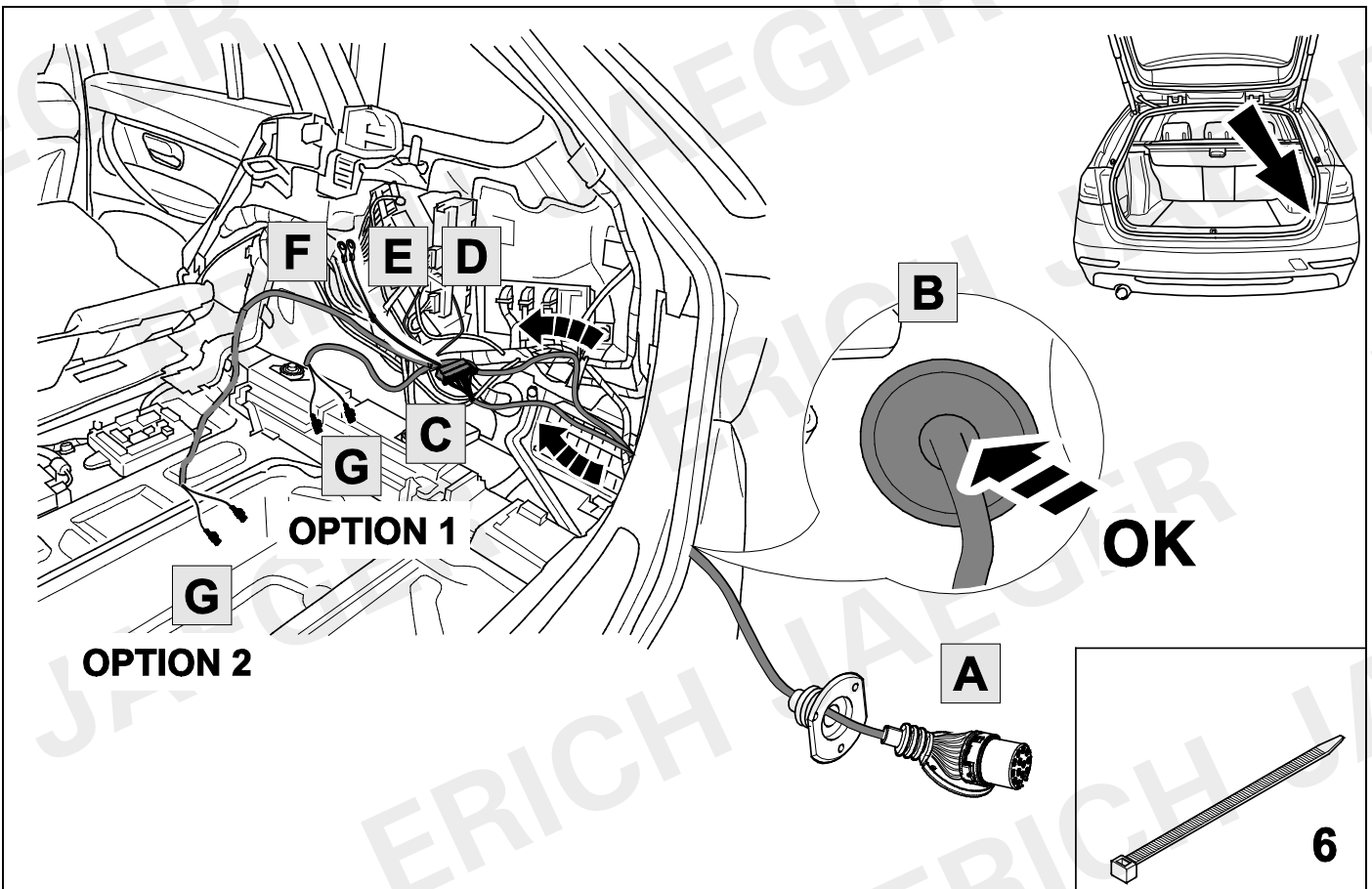

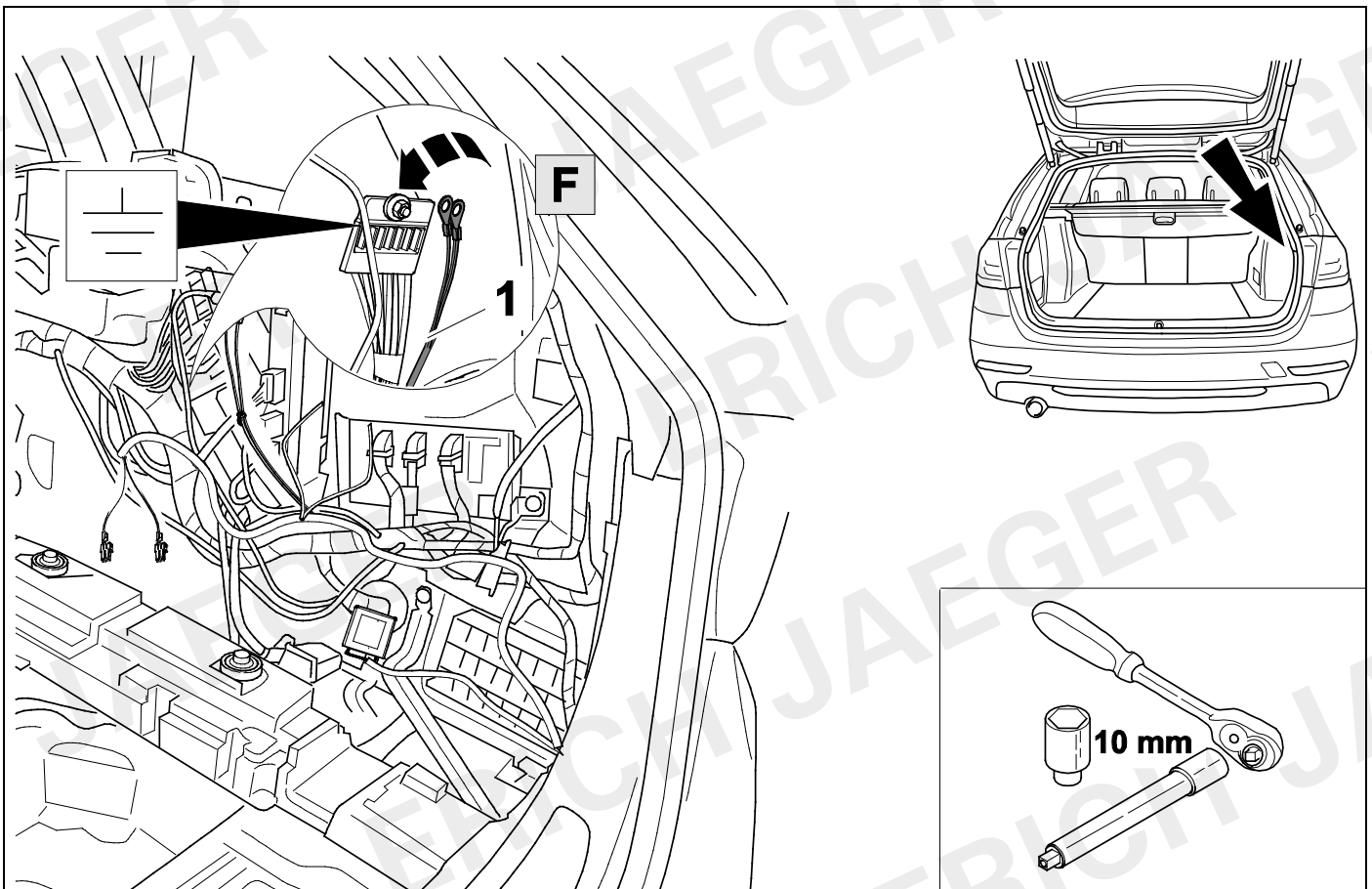
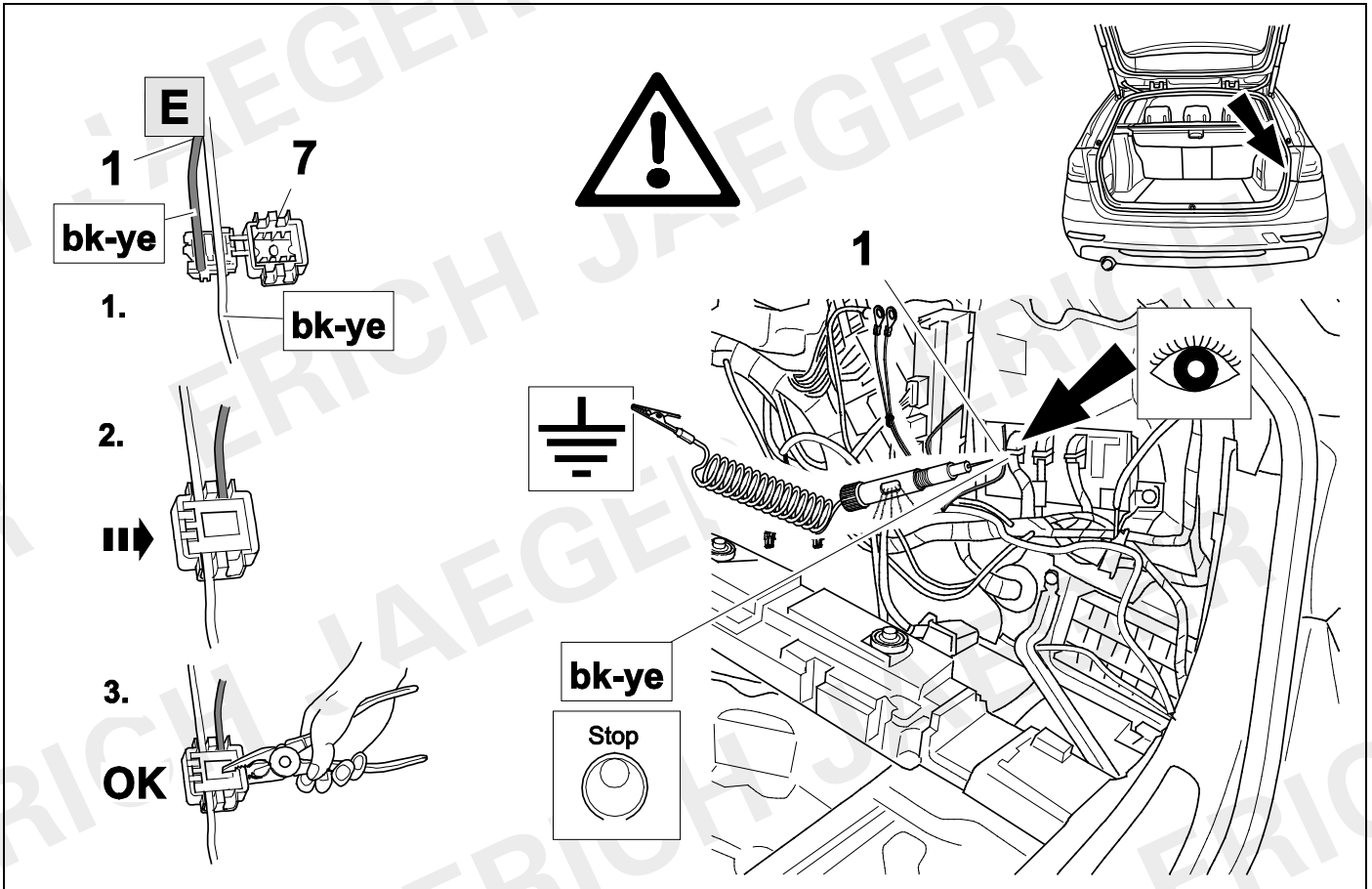

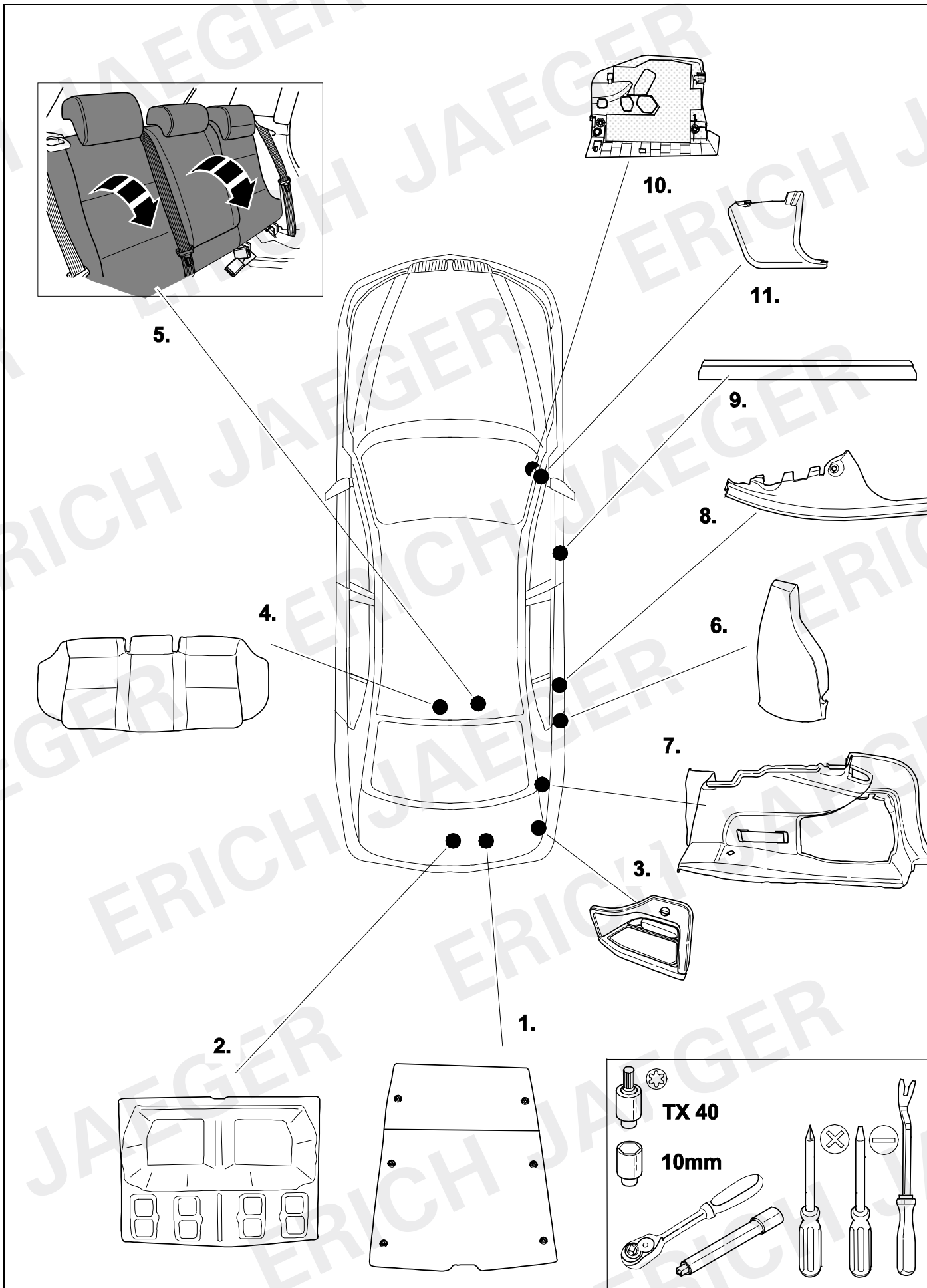

26

F32

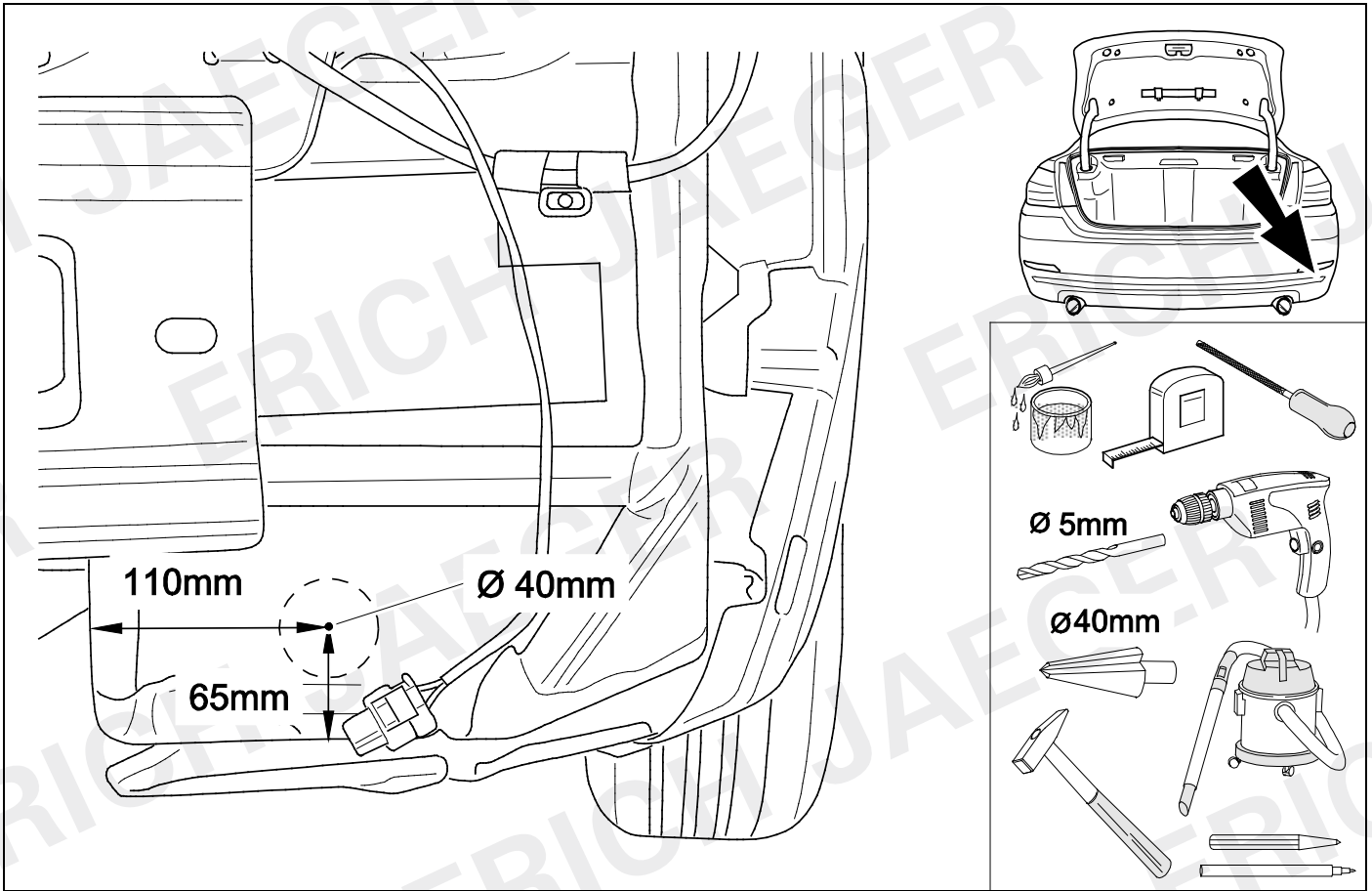

27

F32

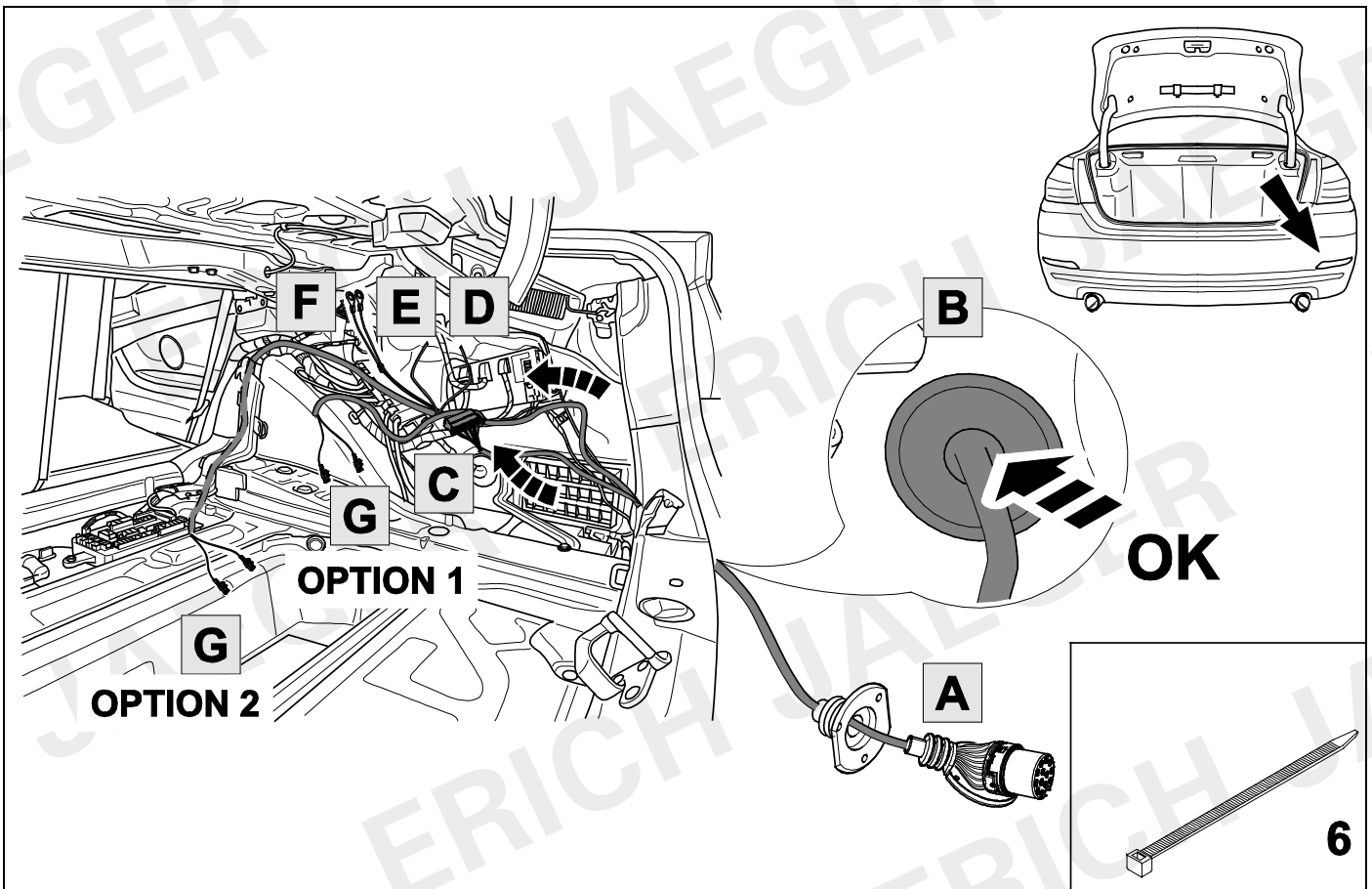

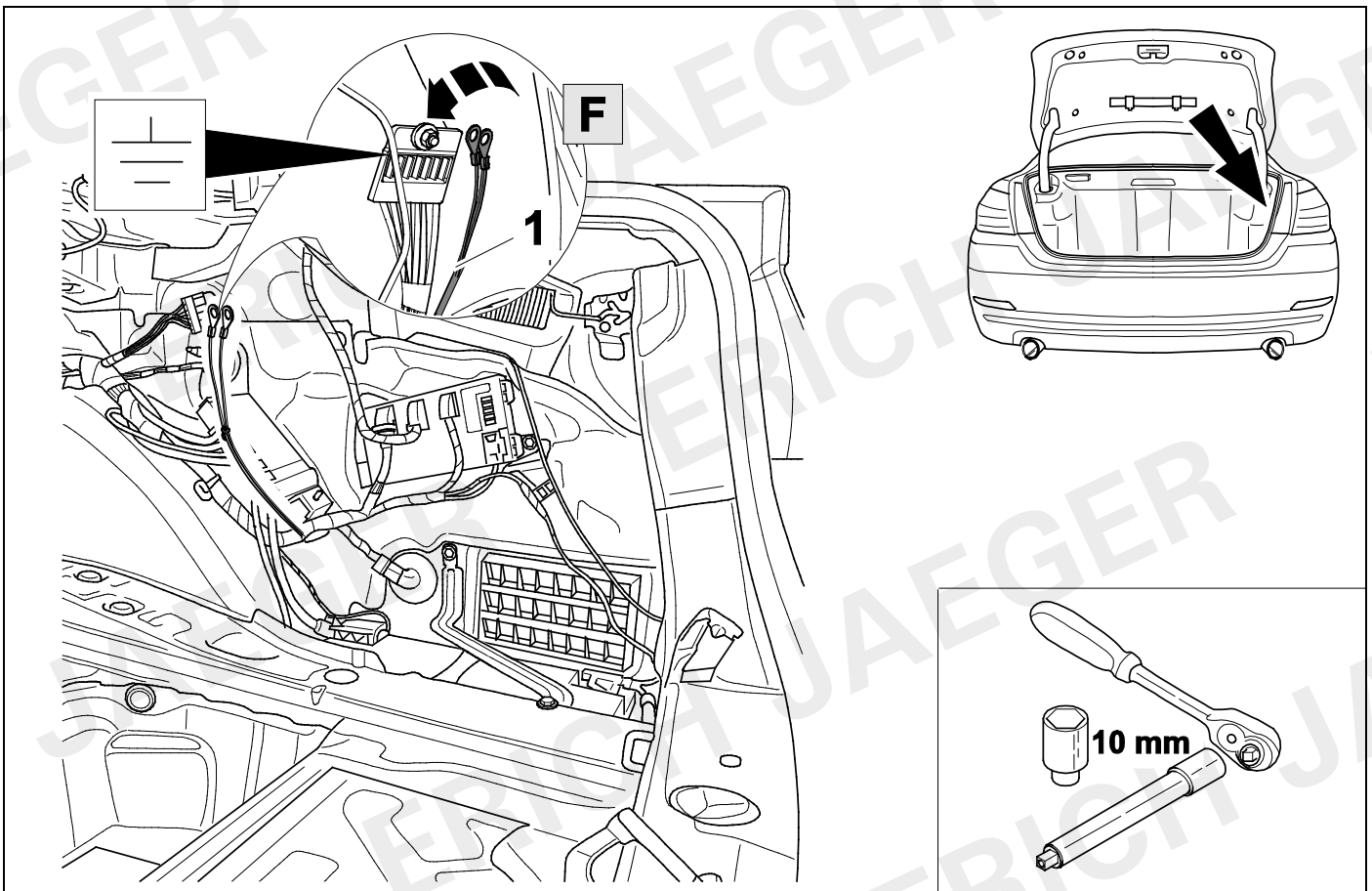
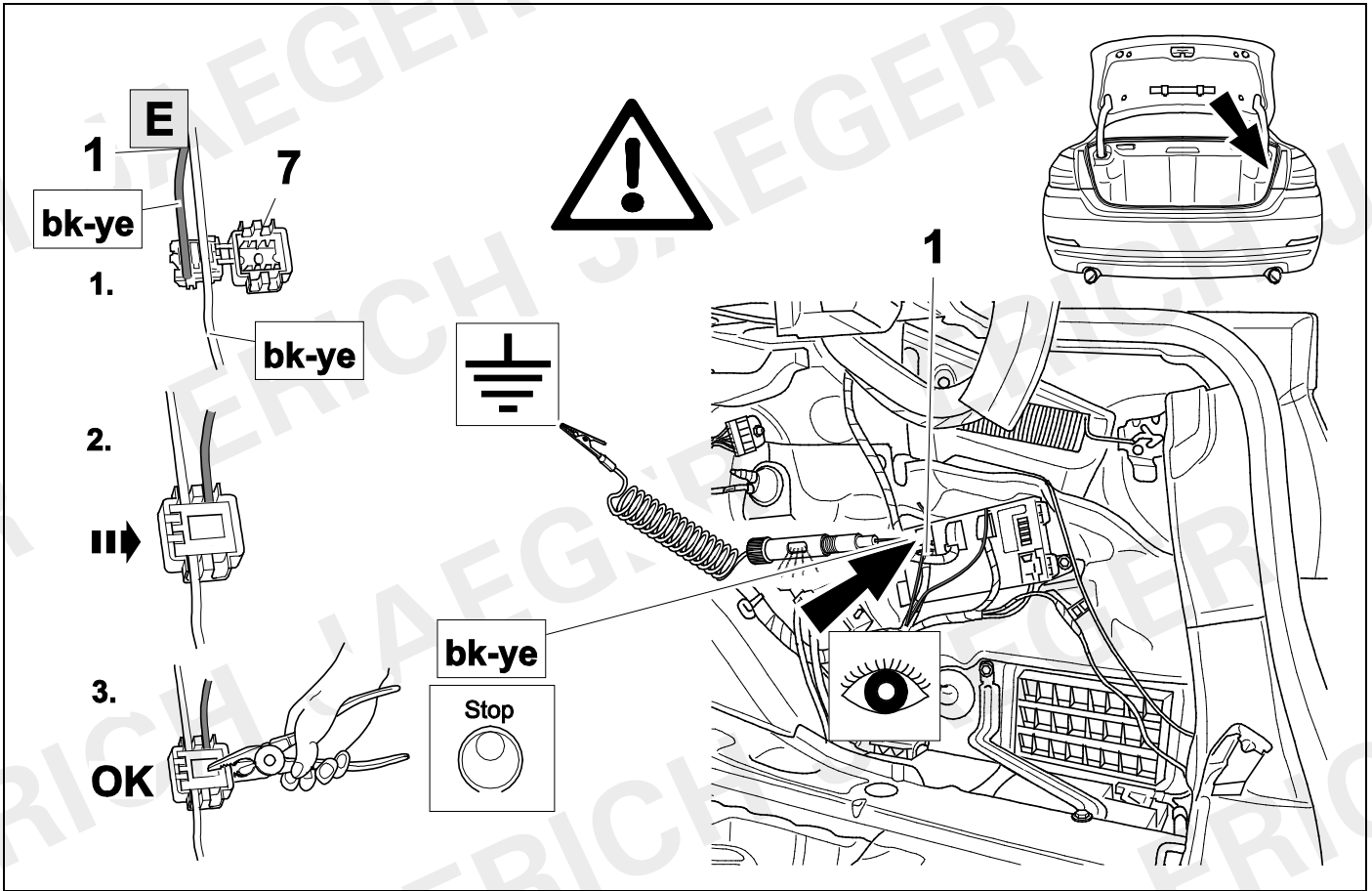

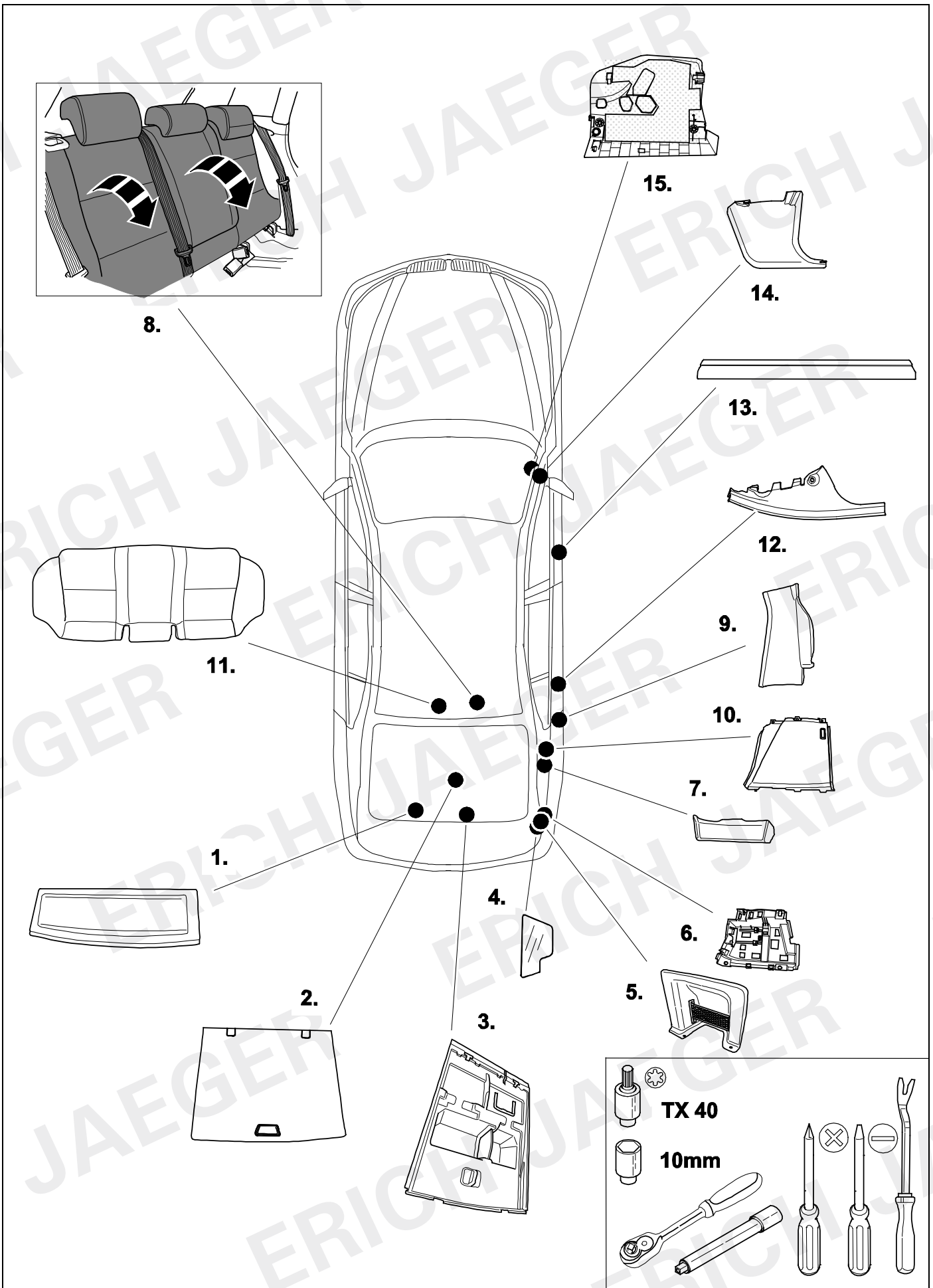

33

F34

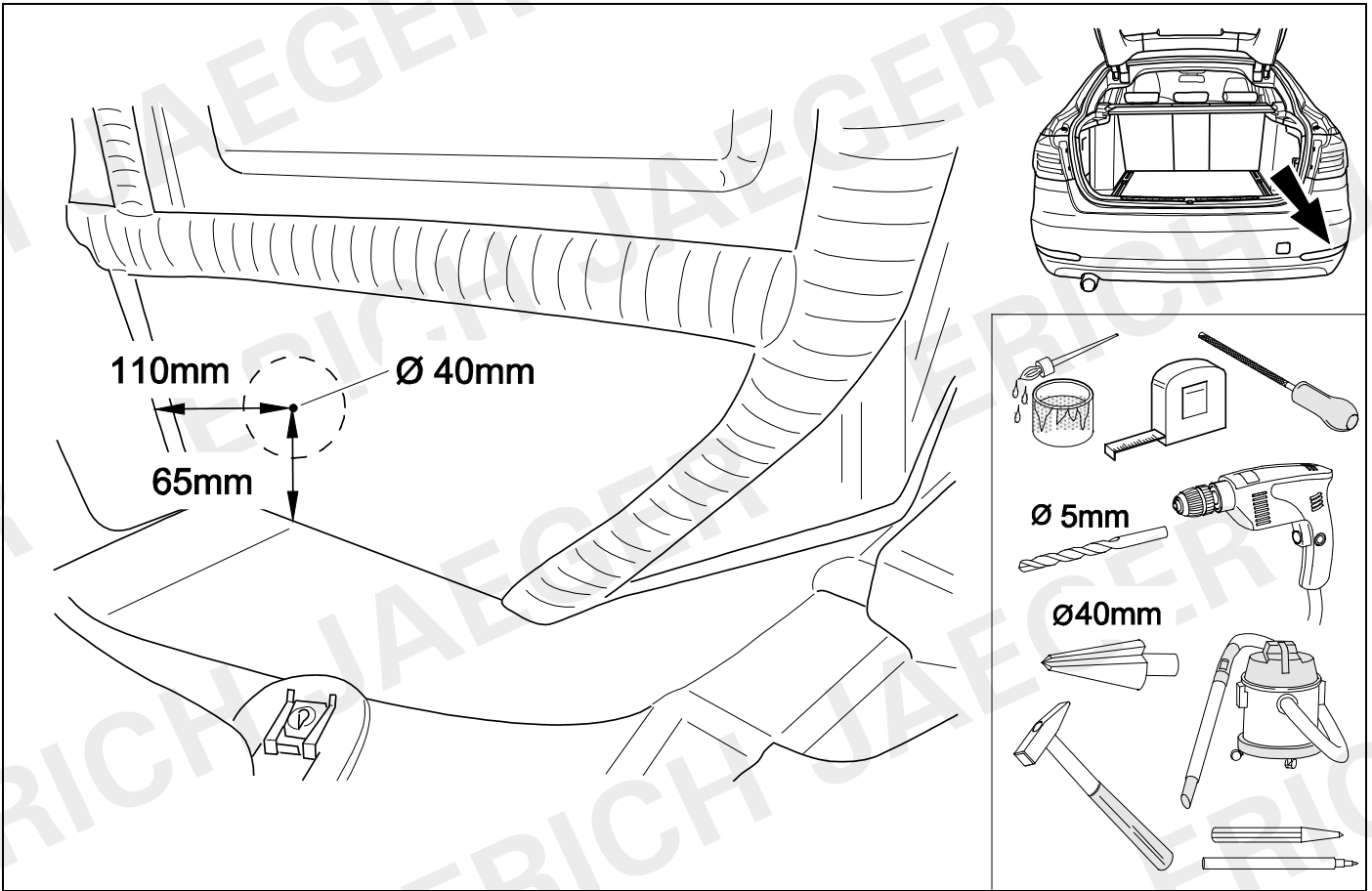

34

F34

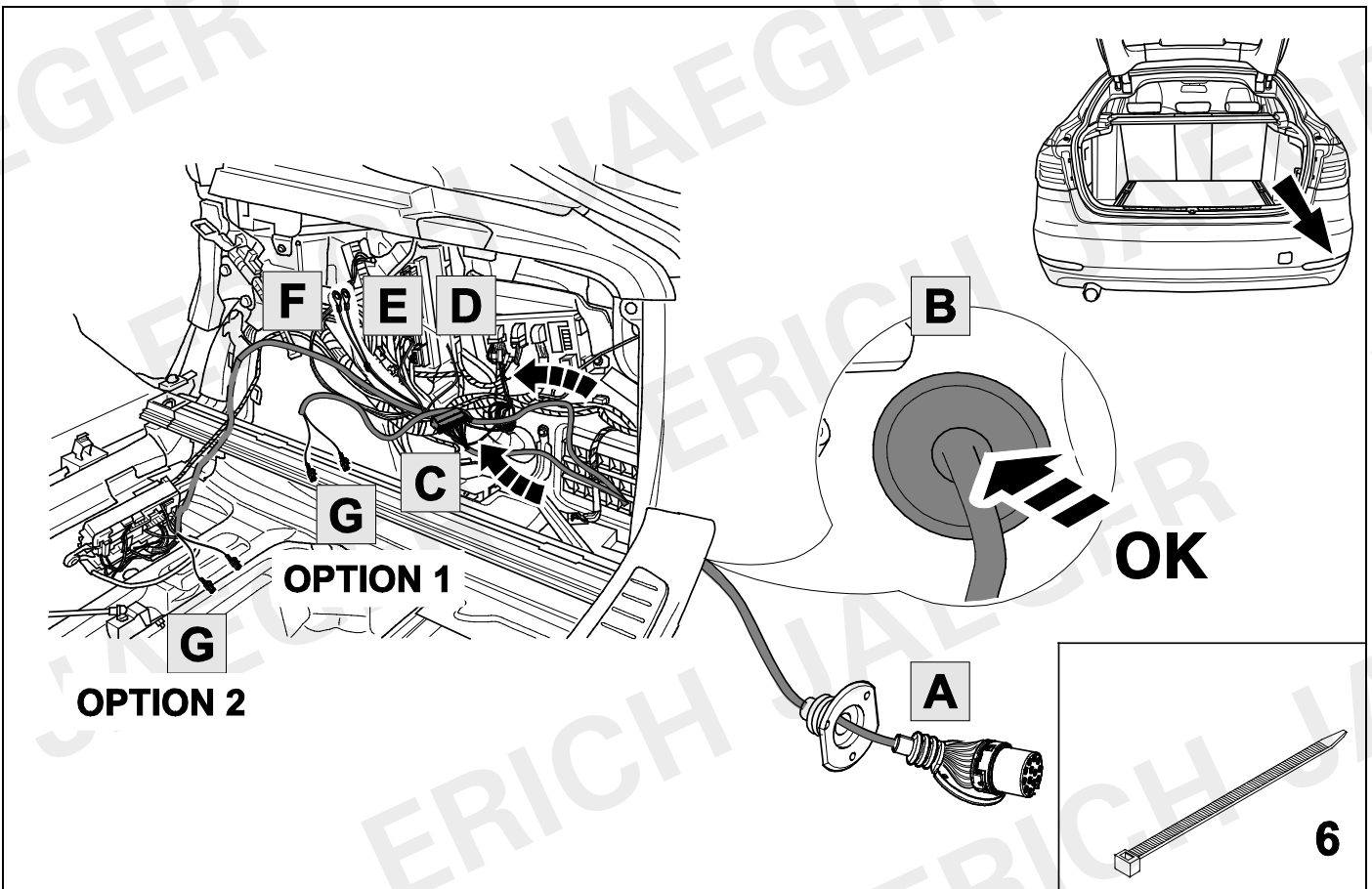

35

F34

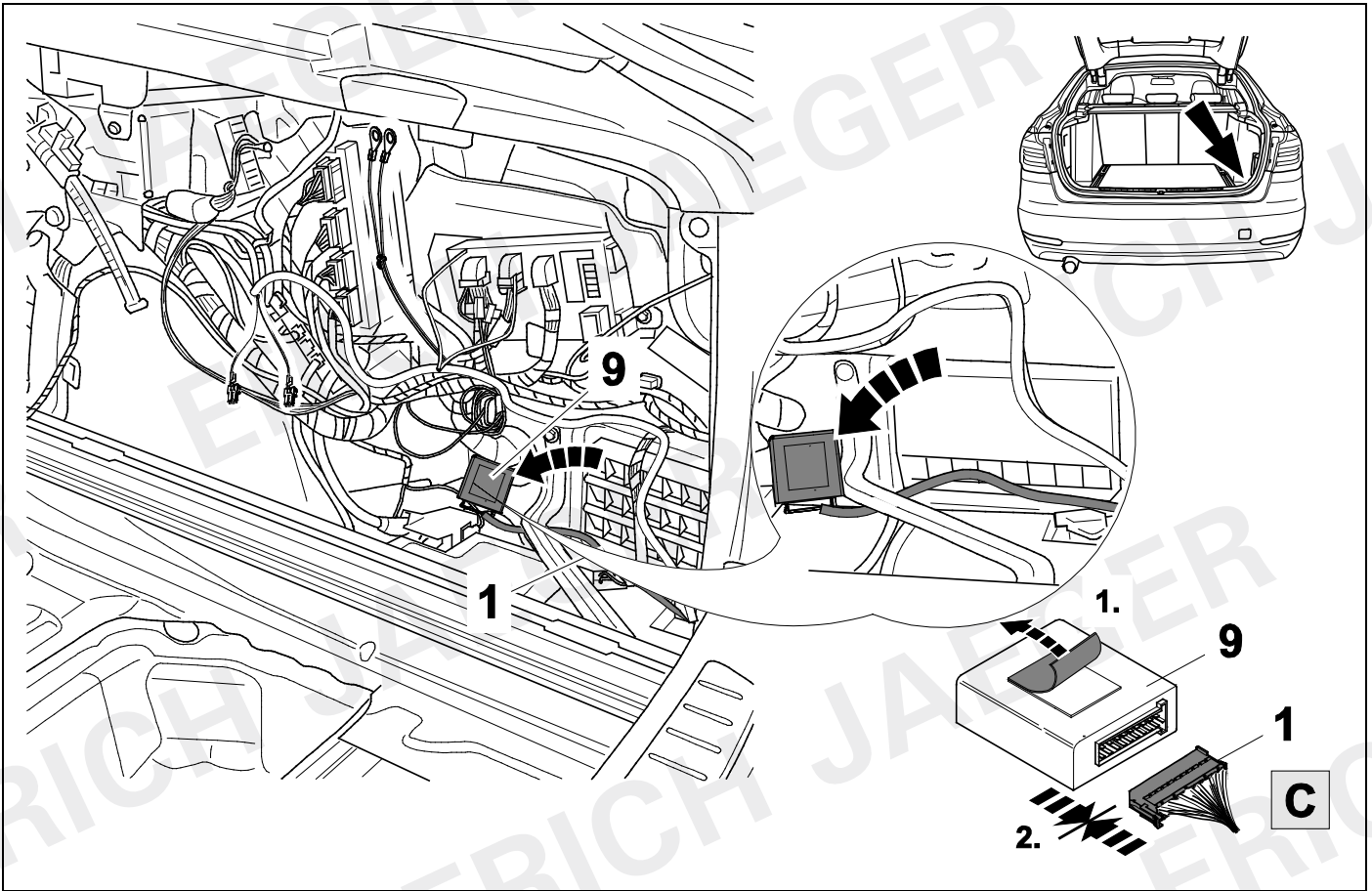

36



55

F34

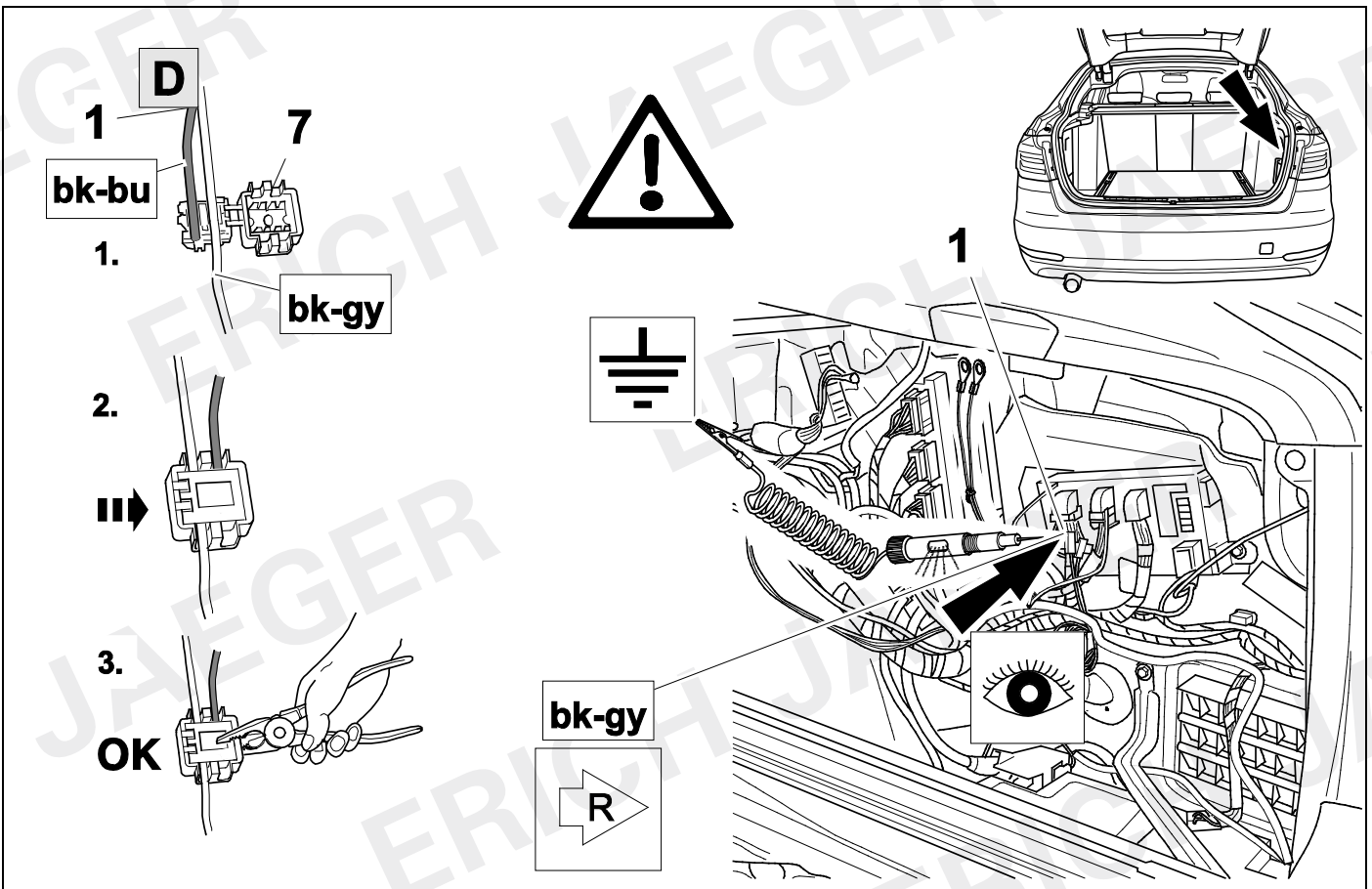

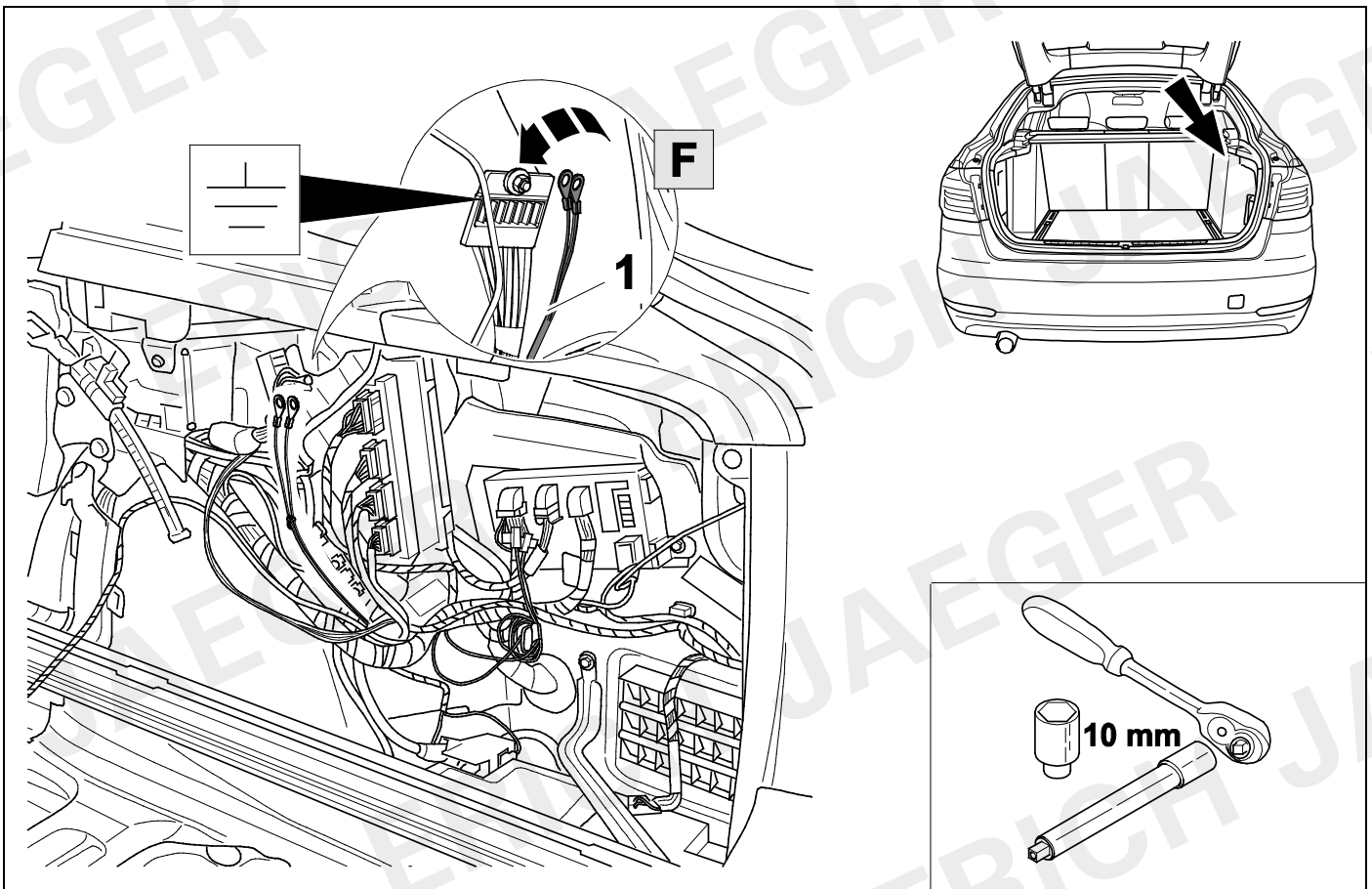
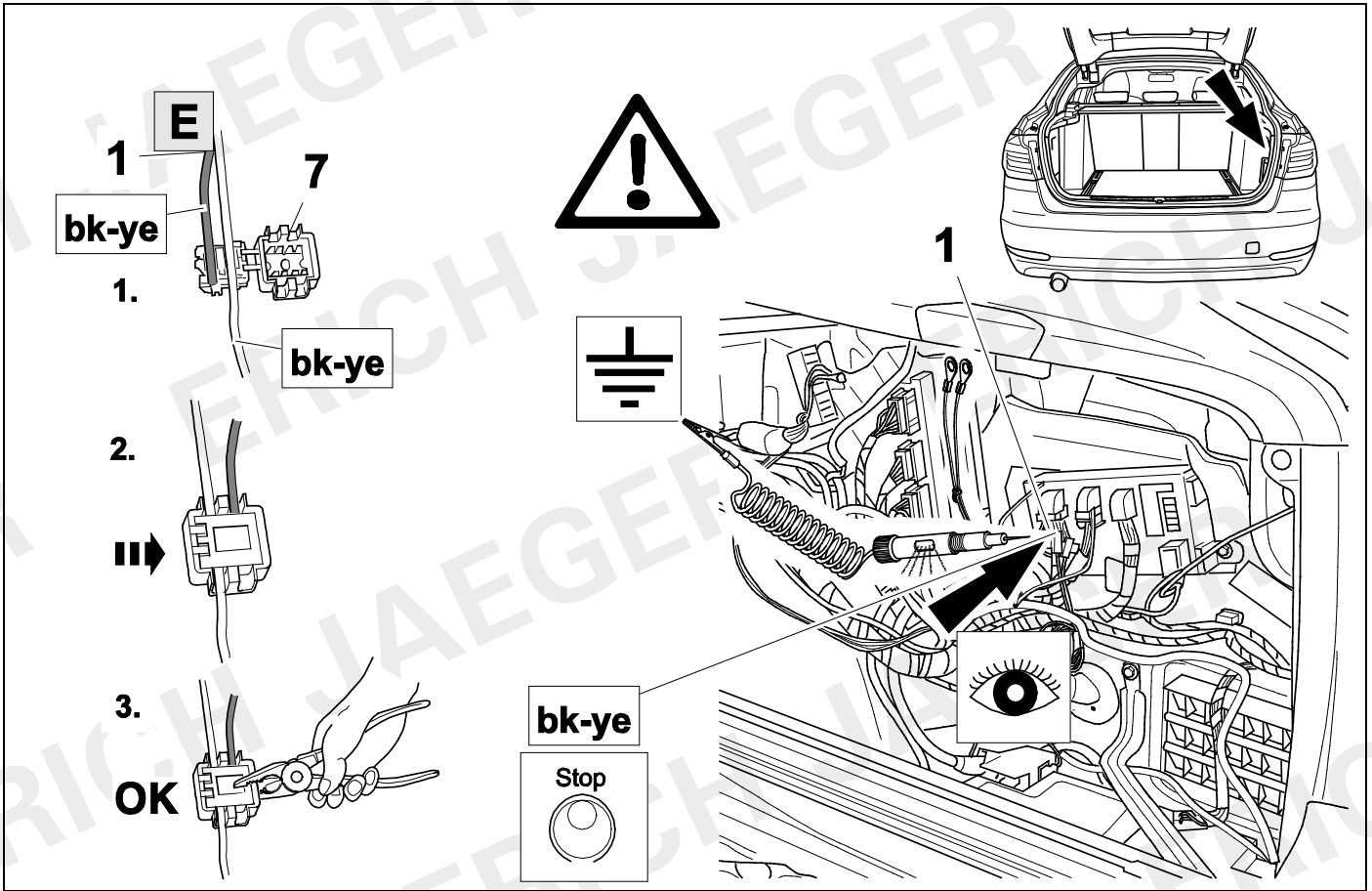

39

F20

F30

F31

F32

F34

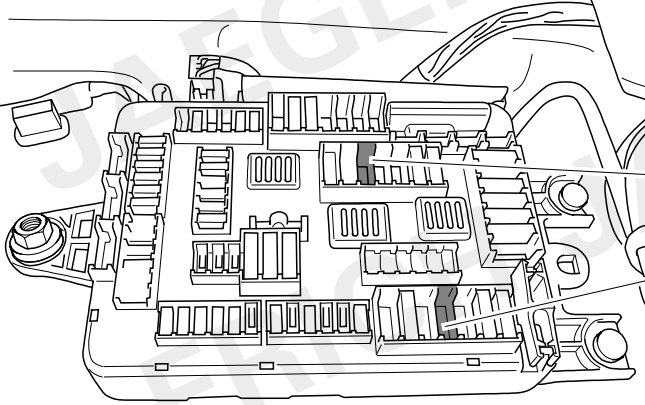

OPTION 1

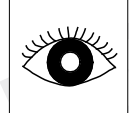
 **F113** → **40 - 42**

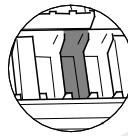
F139  **47 - 65**



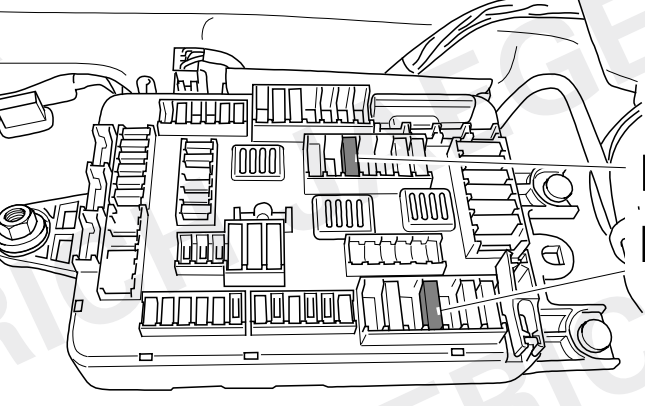

OPTION 2

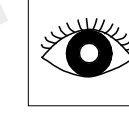
 **F113 20A** → **43 - 65**

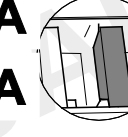
F139 20A 



40

OPTION 1

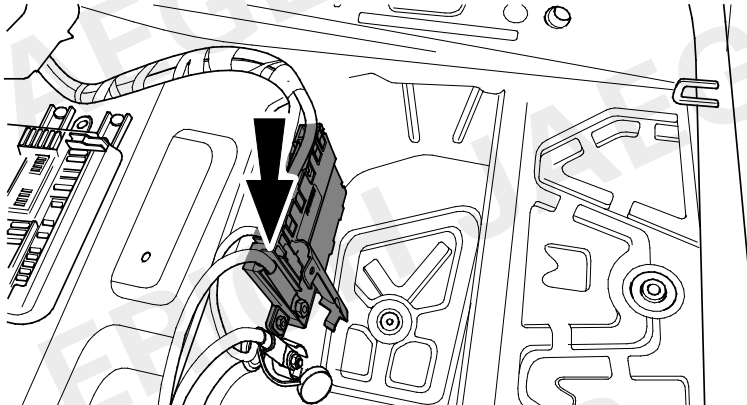

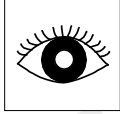
 **F20** →

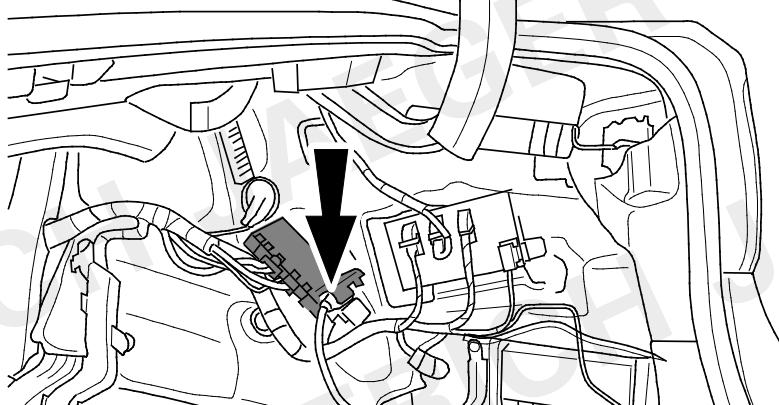

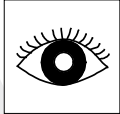
 → **F30**
F31
F32
F34

41

OPTION 1



63

737201

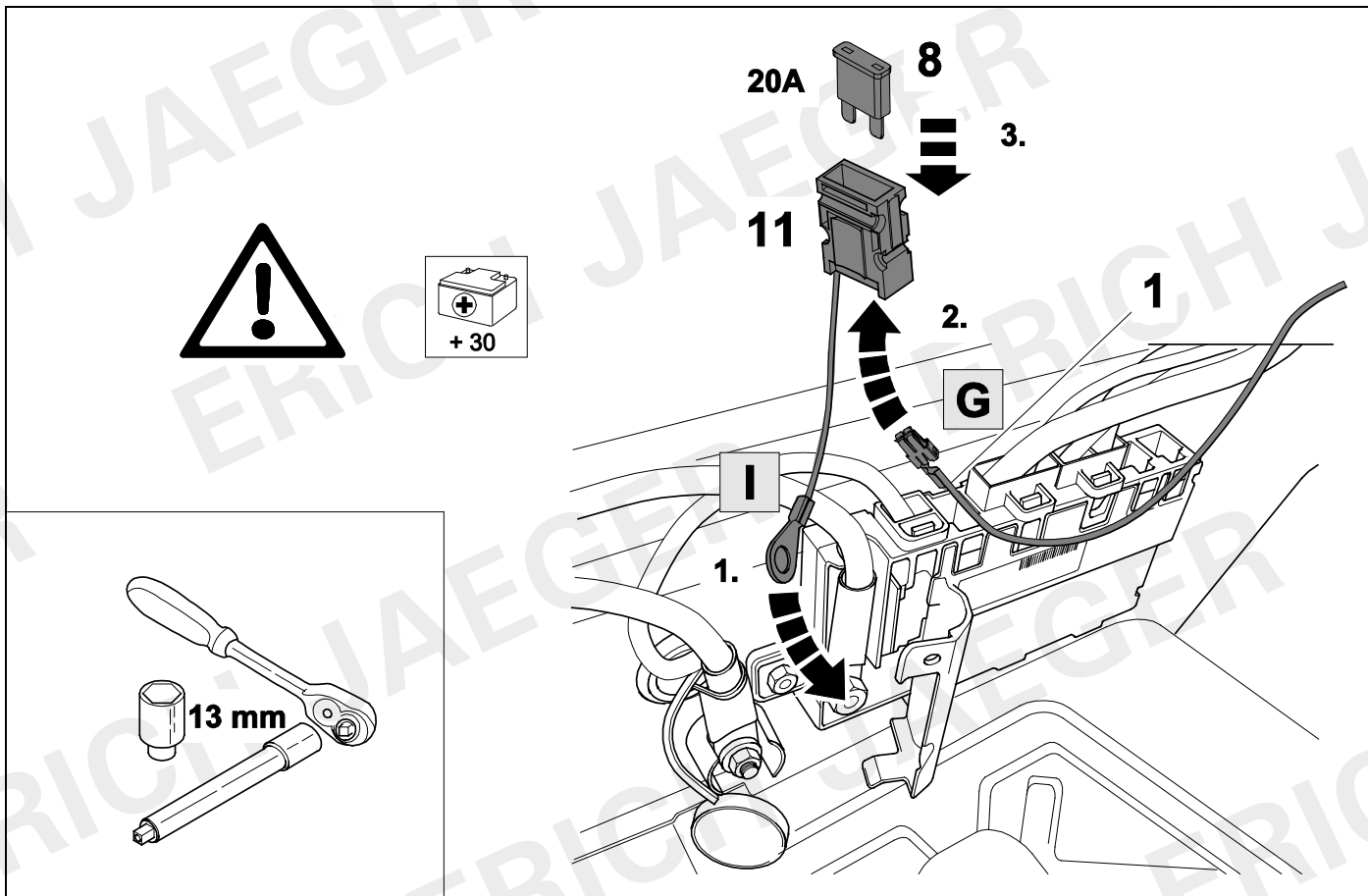

42

OPTION 1



63

748401

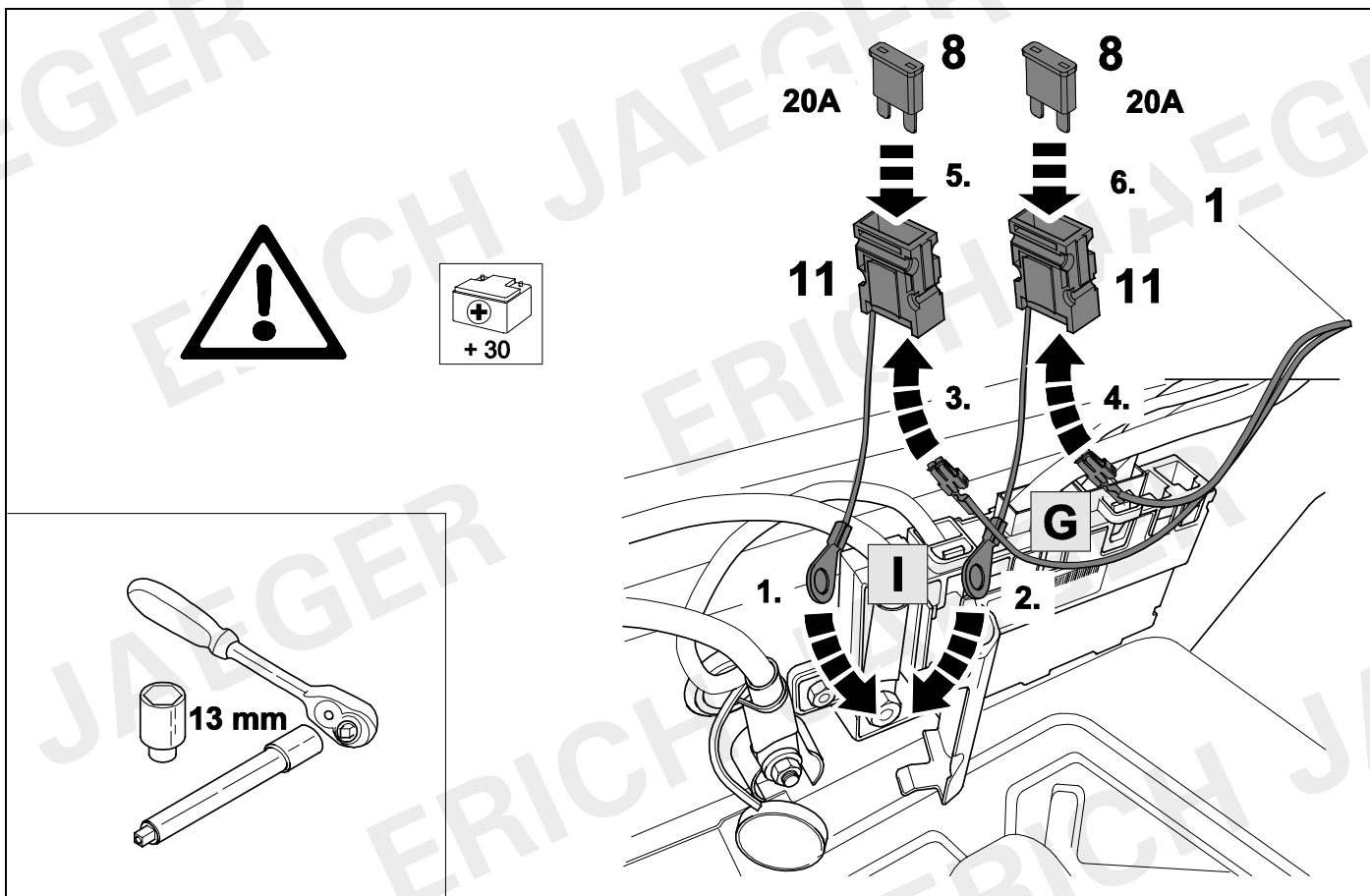

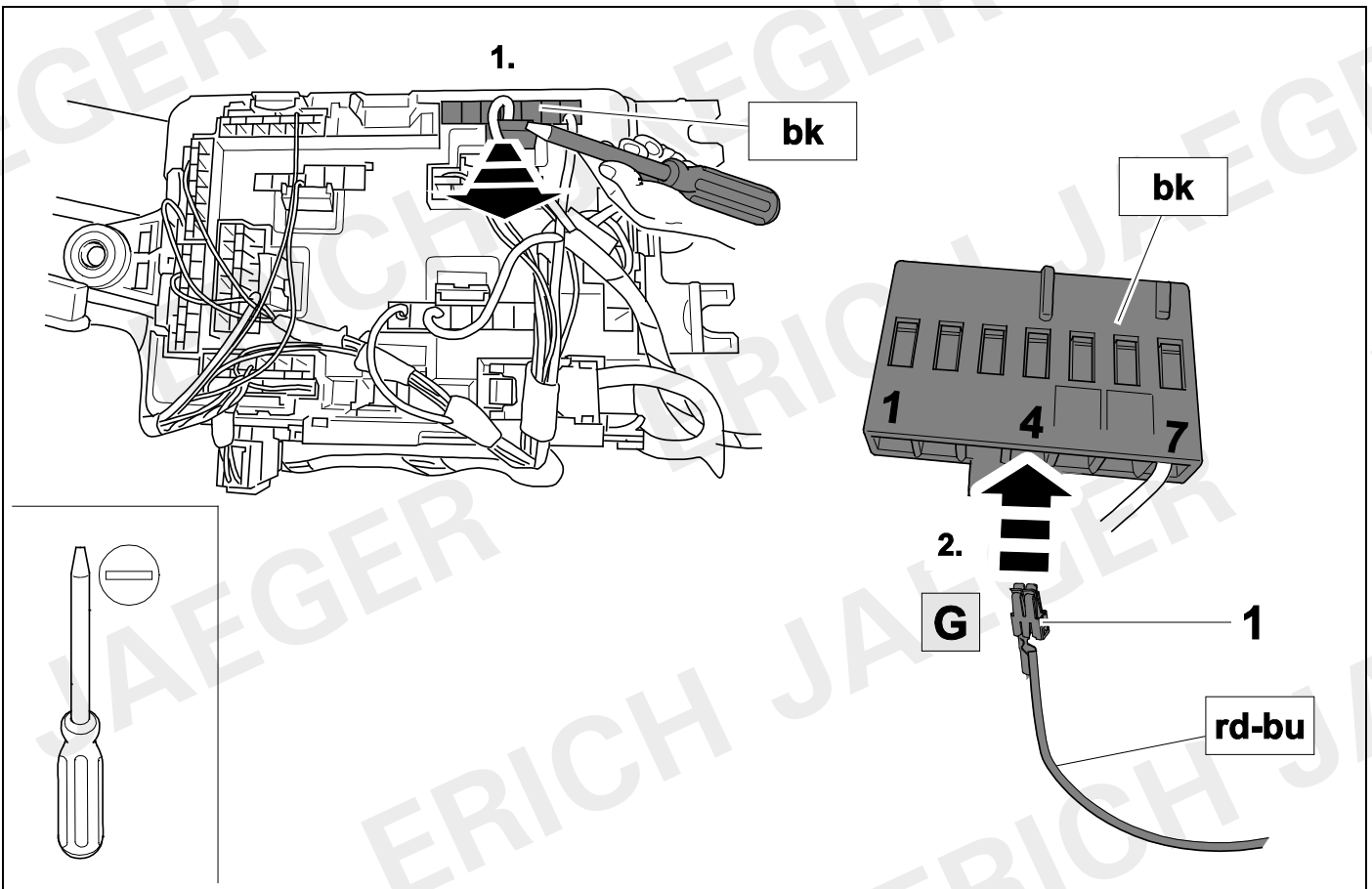
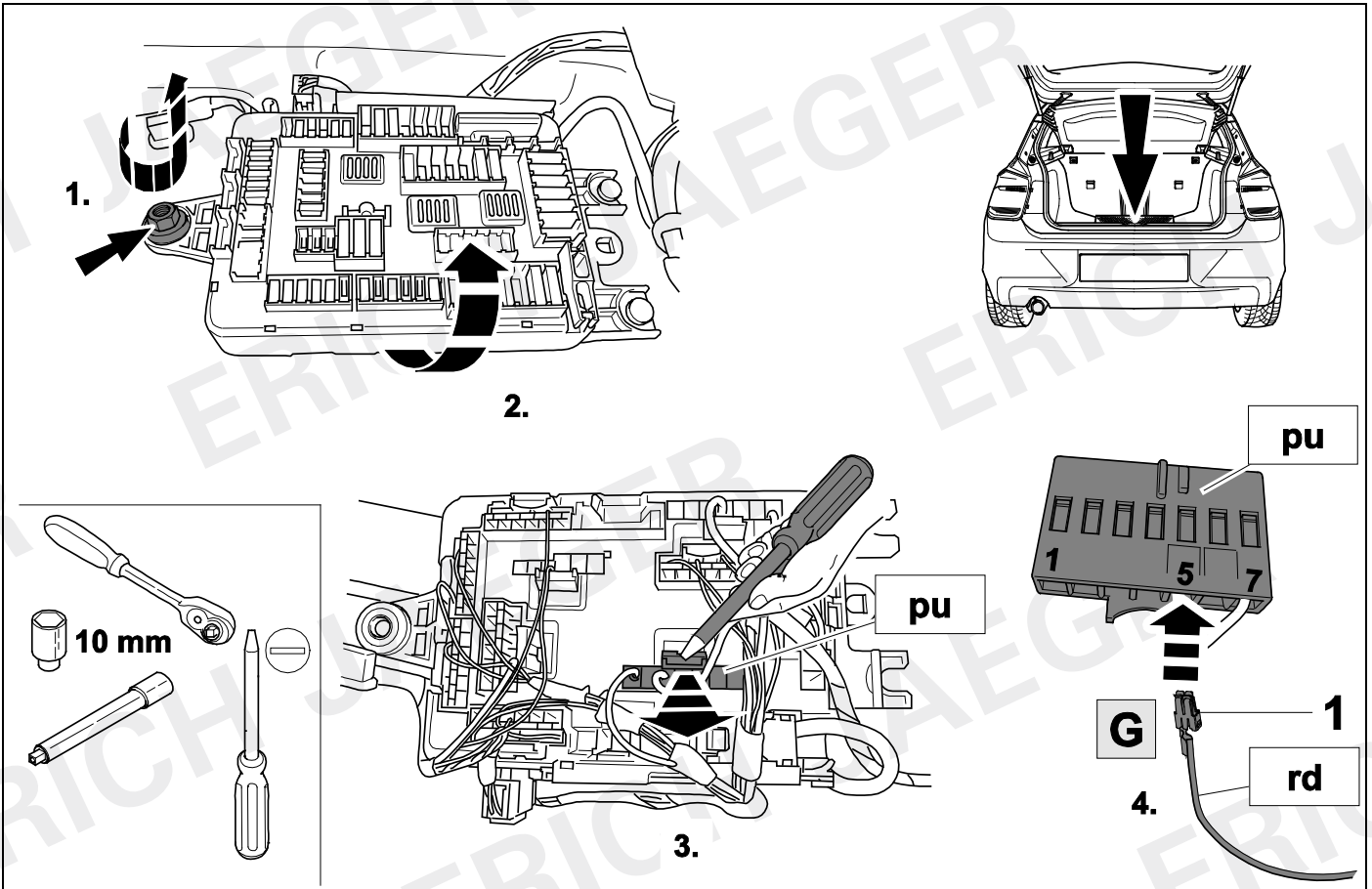

45

OPTION 2



63

737201

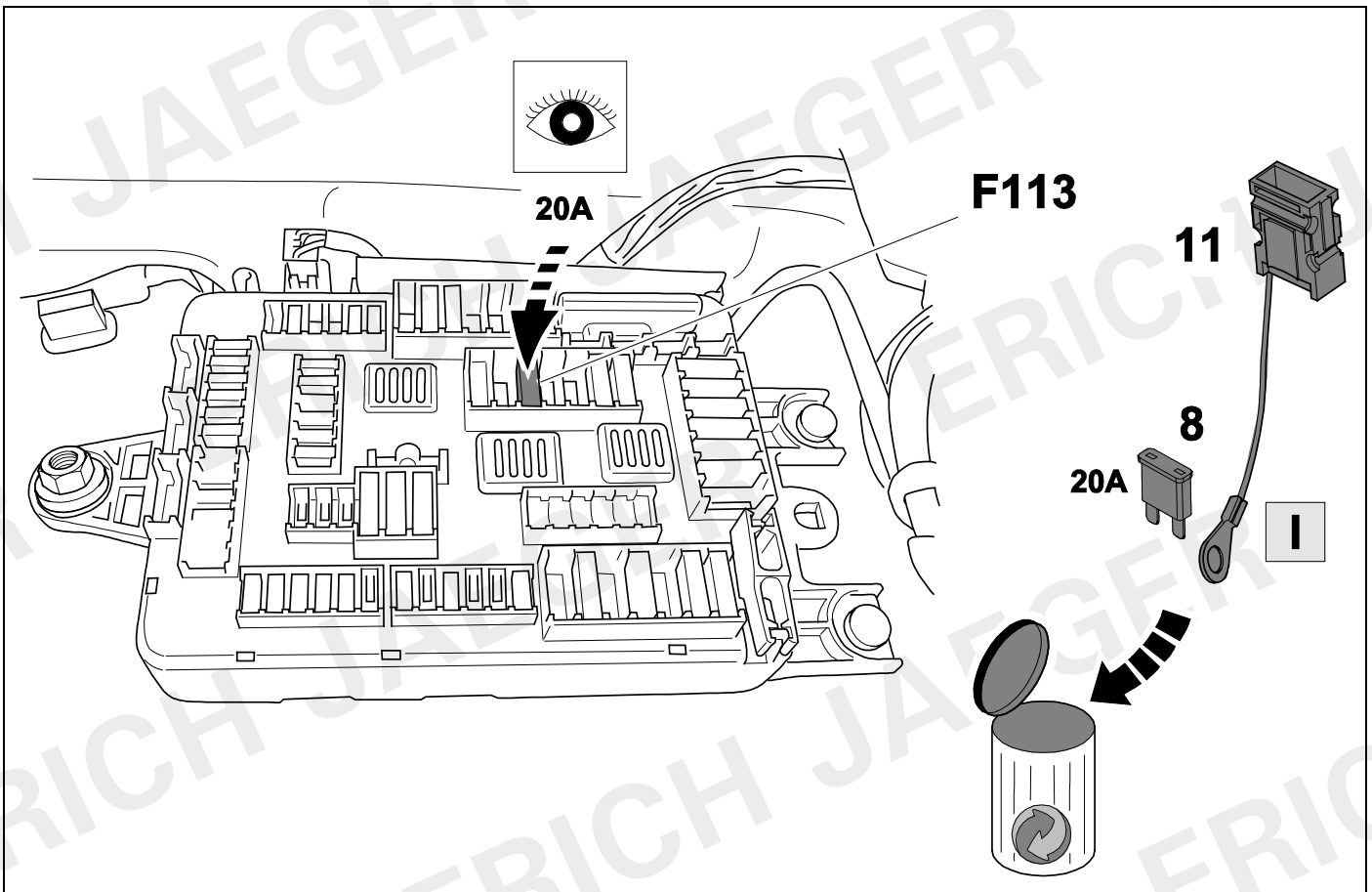

46

OPTION 2



63

748401

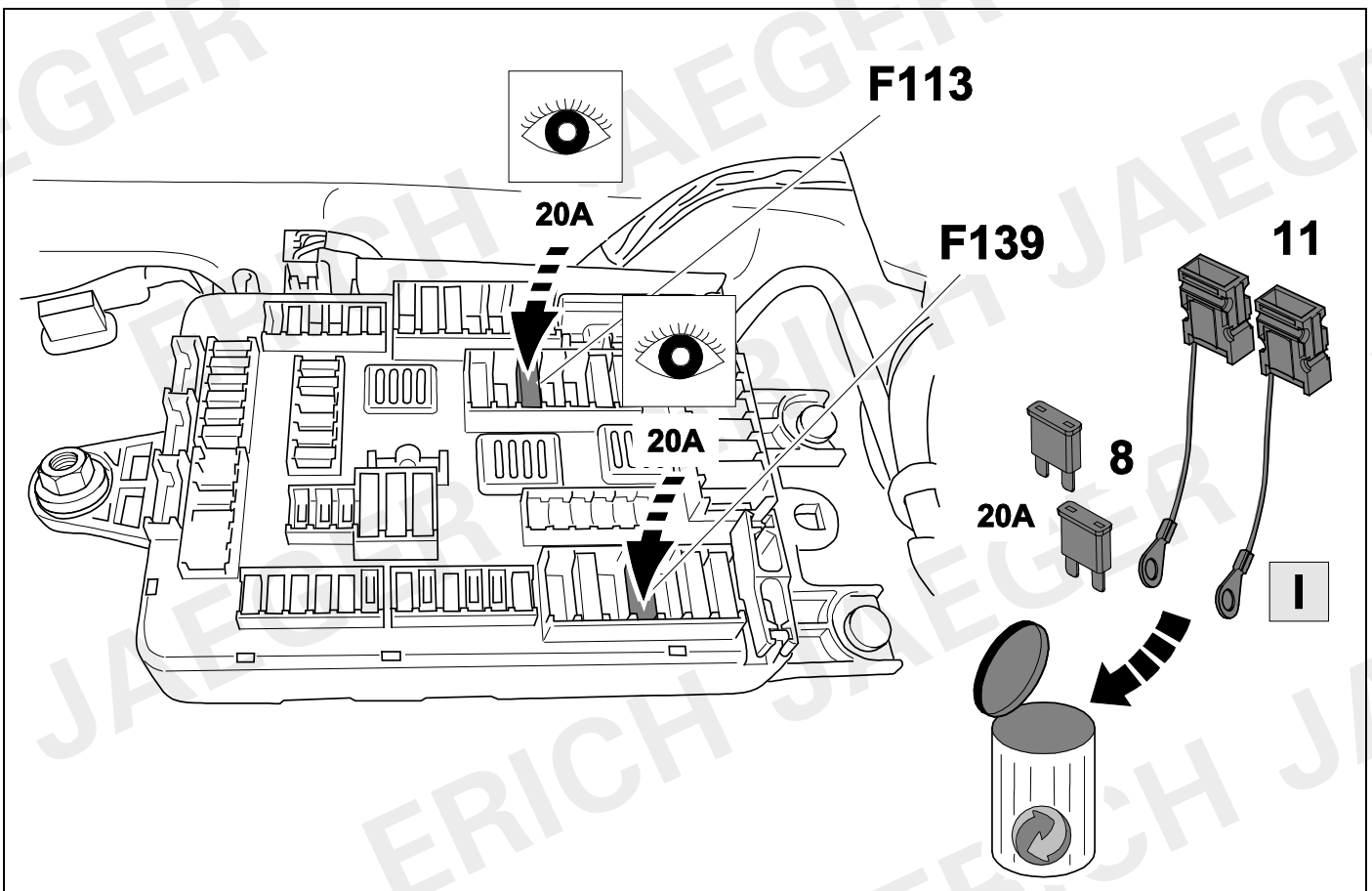

47

F20

F30

F31

F32

F34

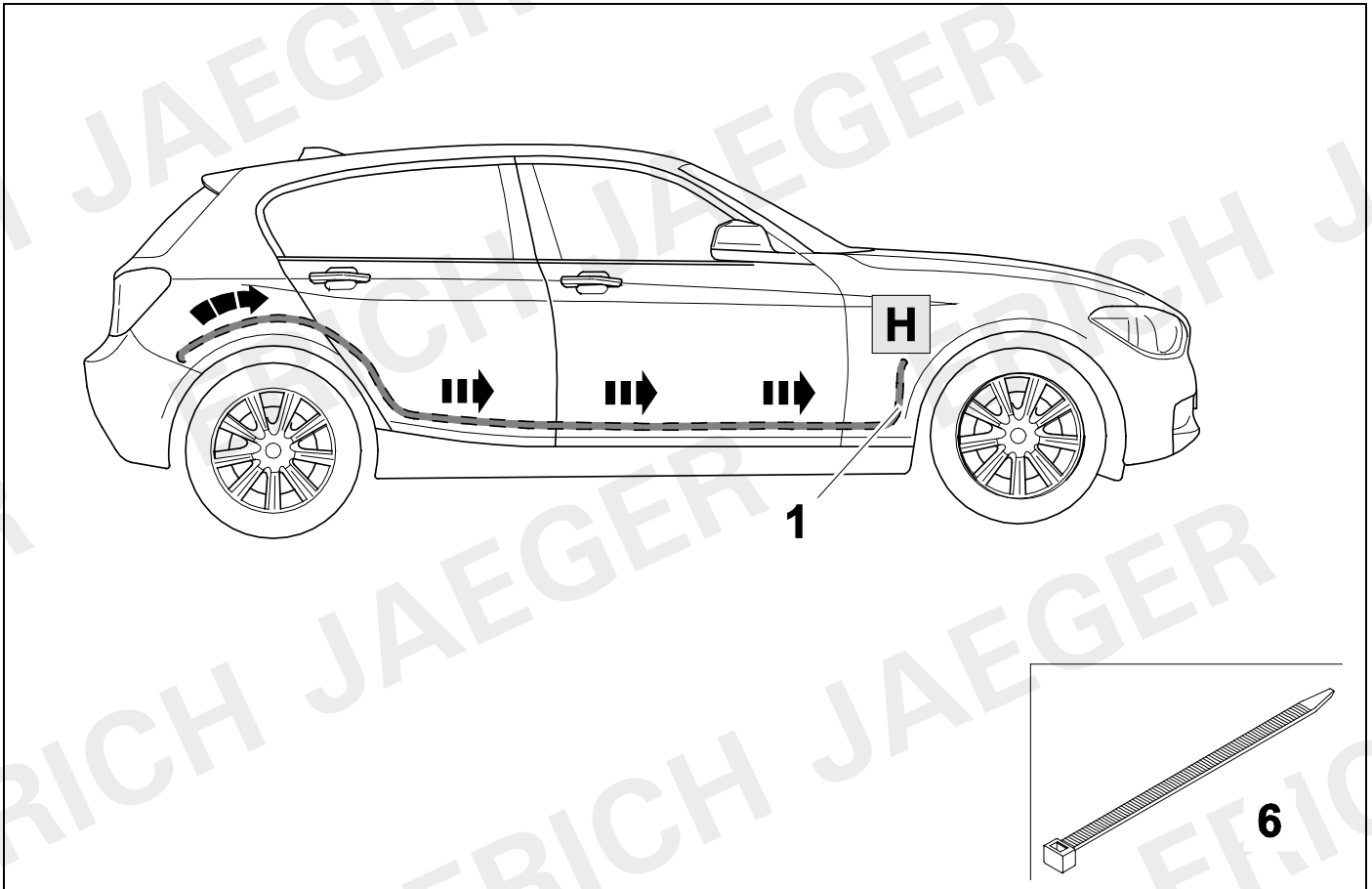

48



55

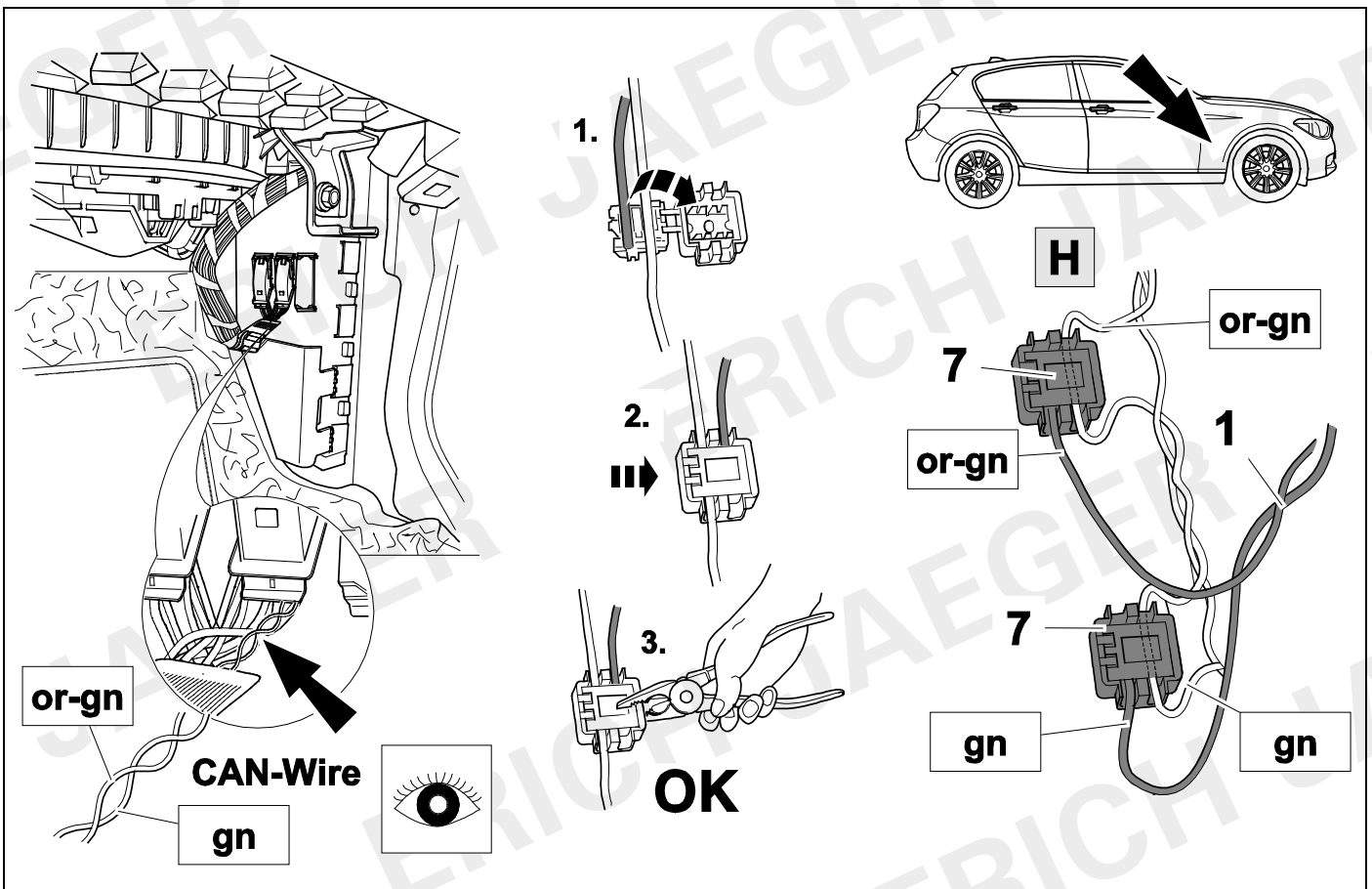

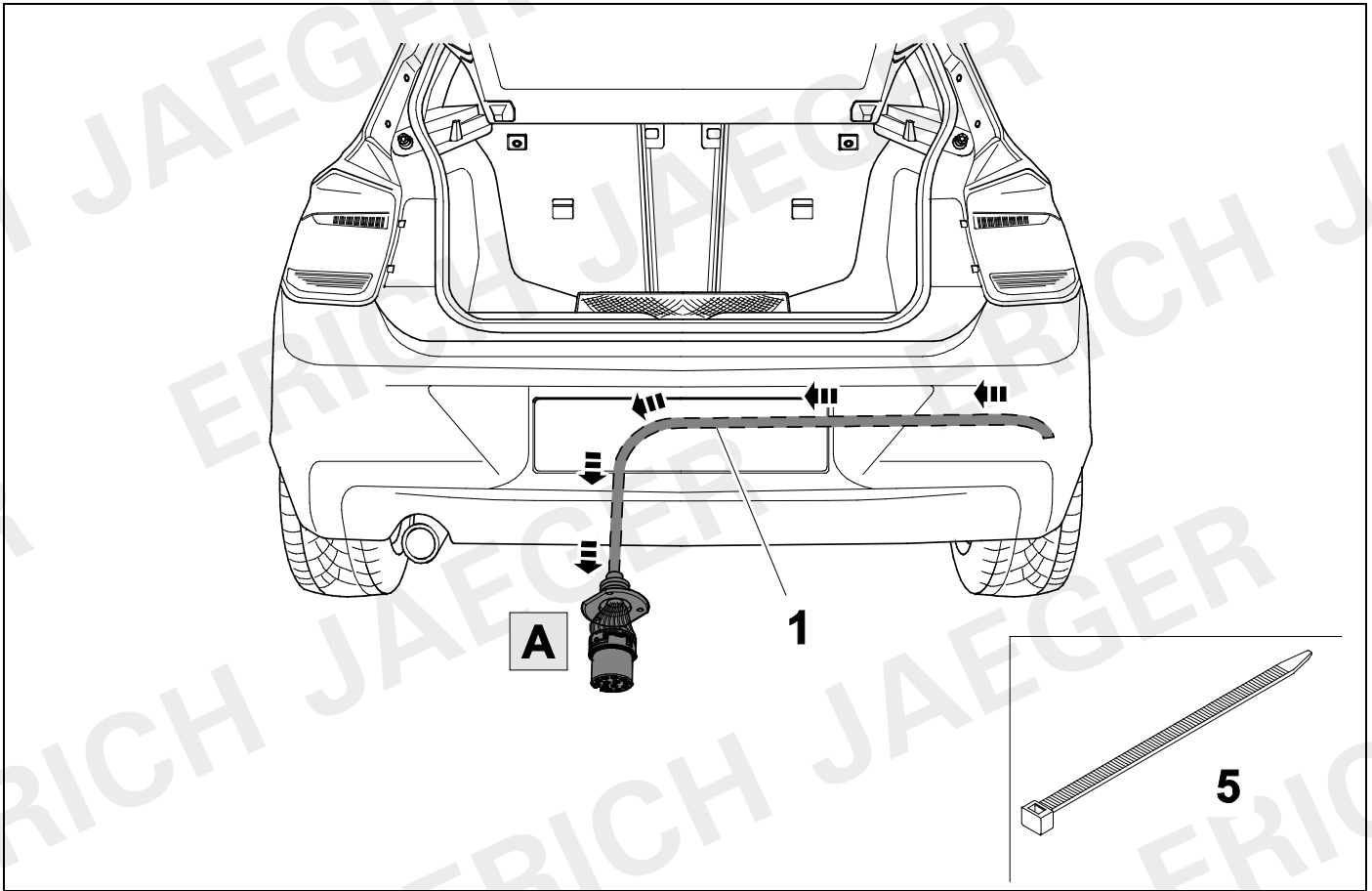

50



54

737201

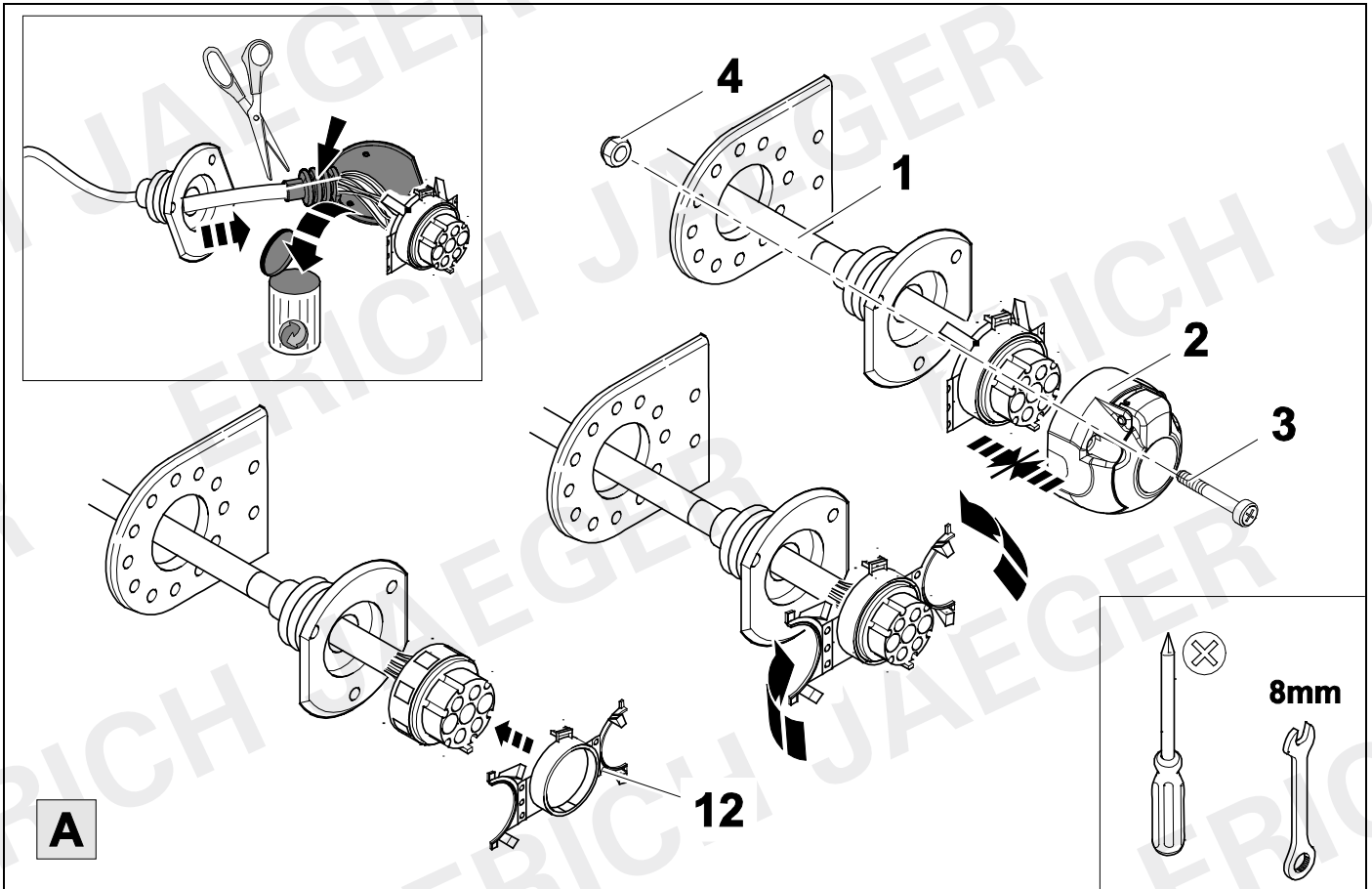

51



54

737201

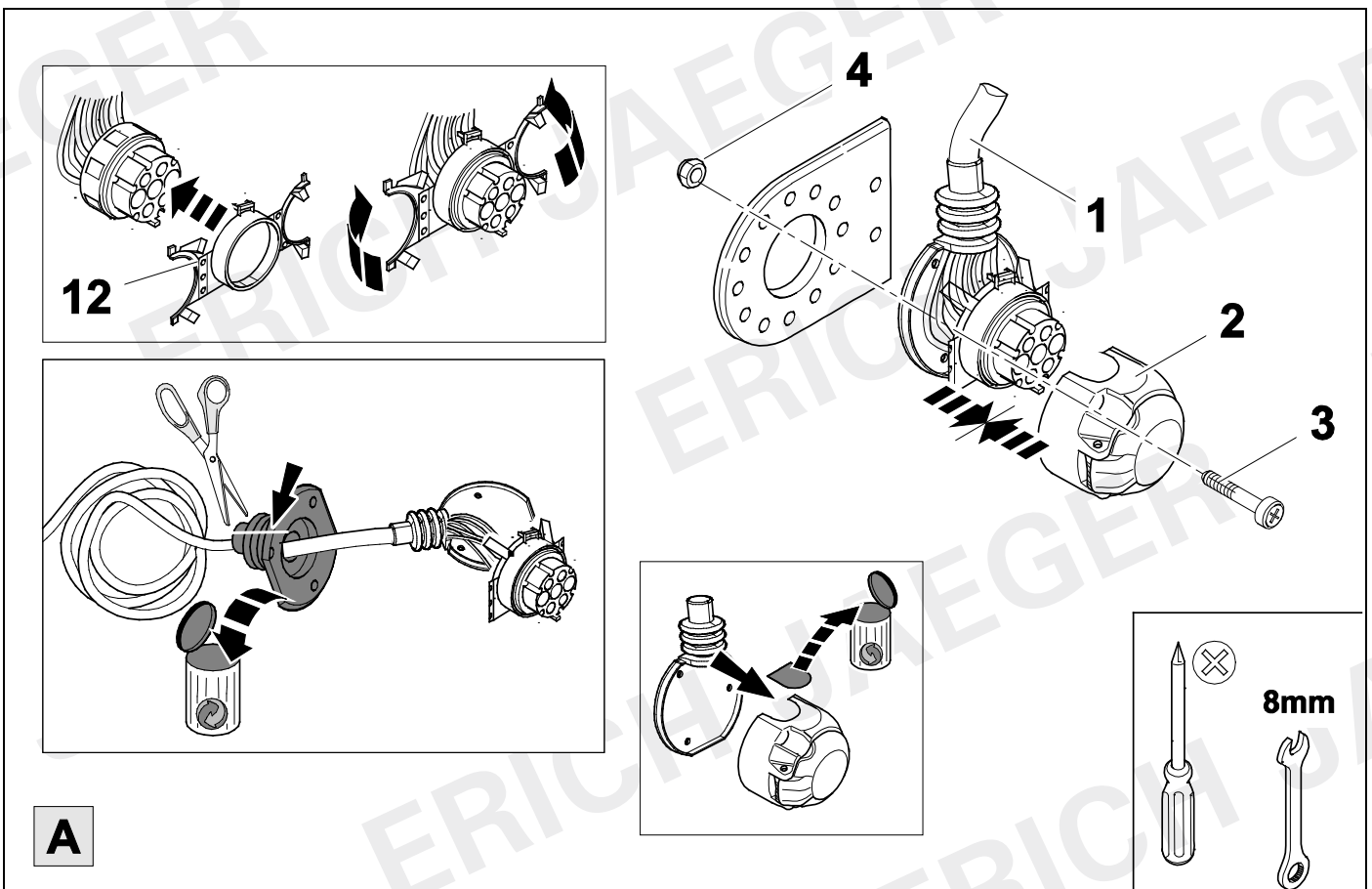

52



54

748401

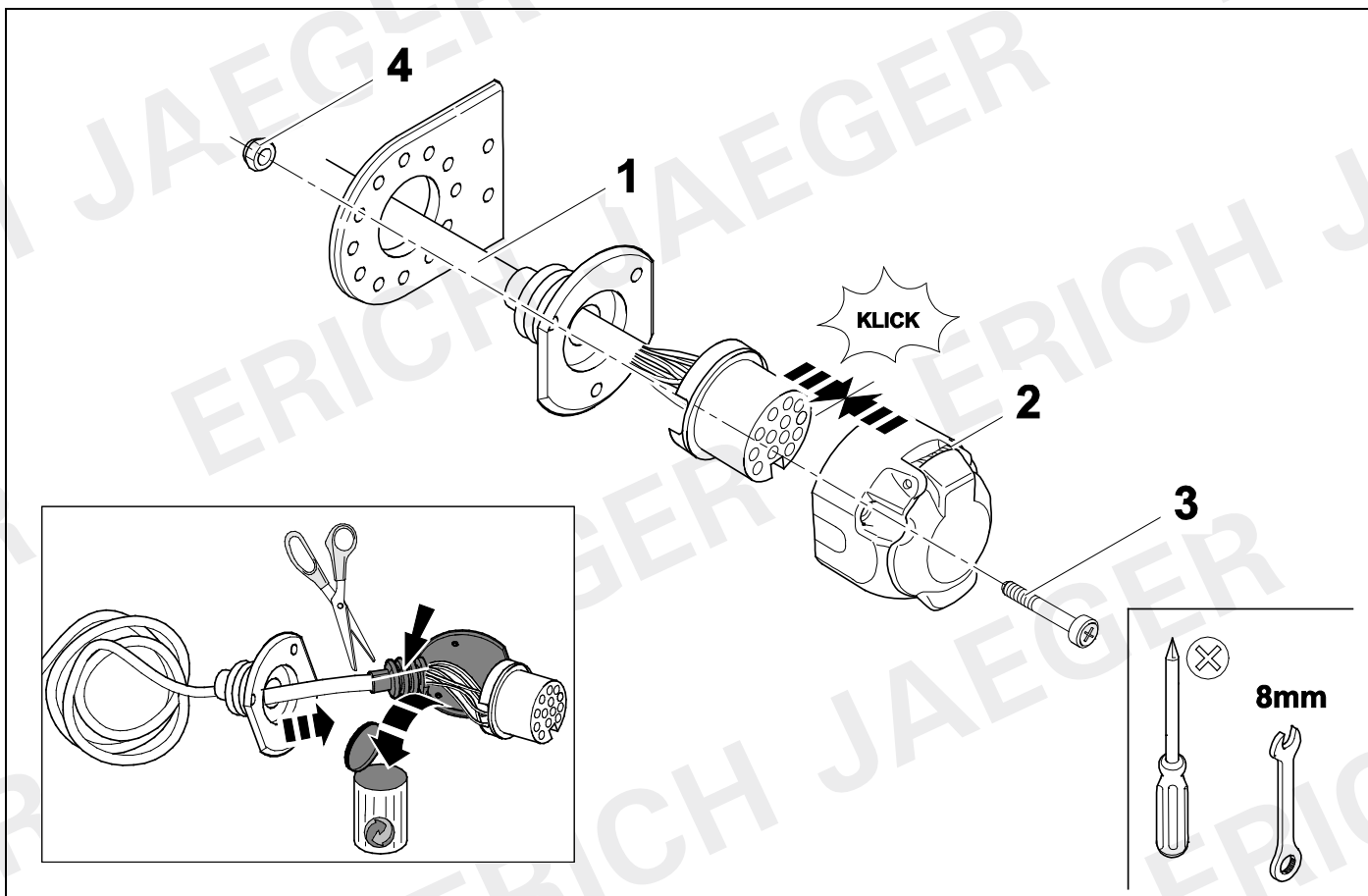

53



54

748401

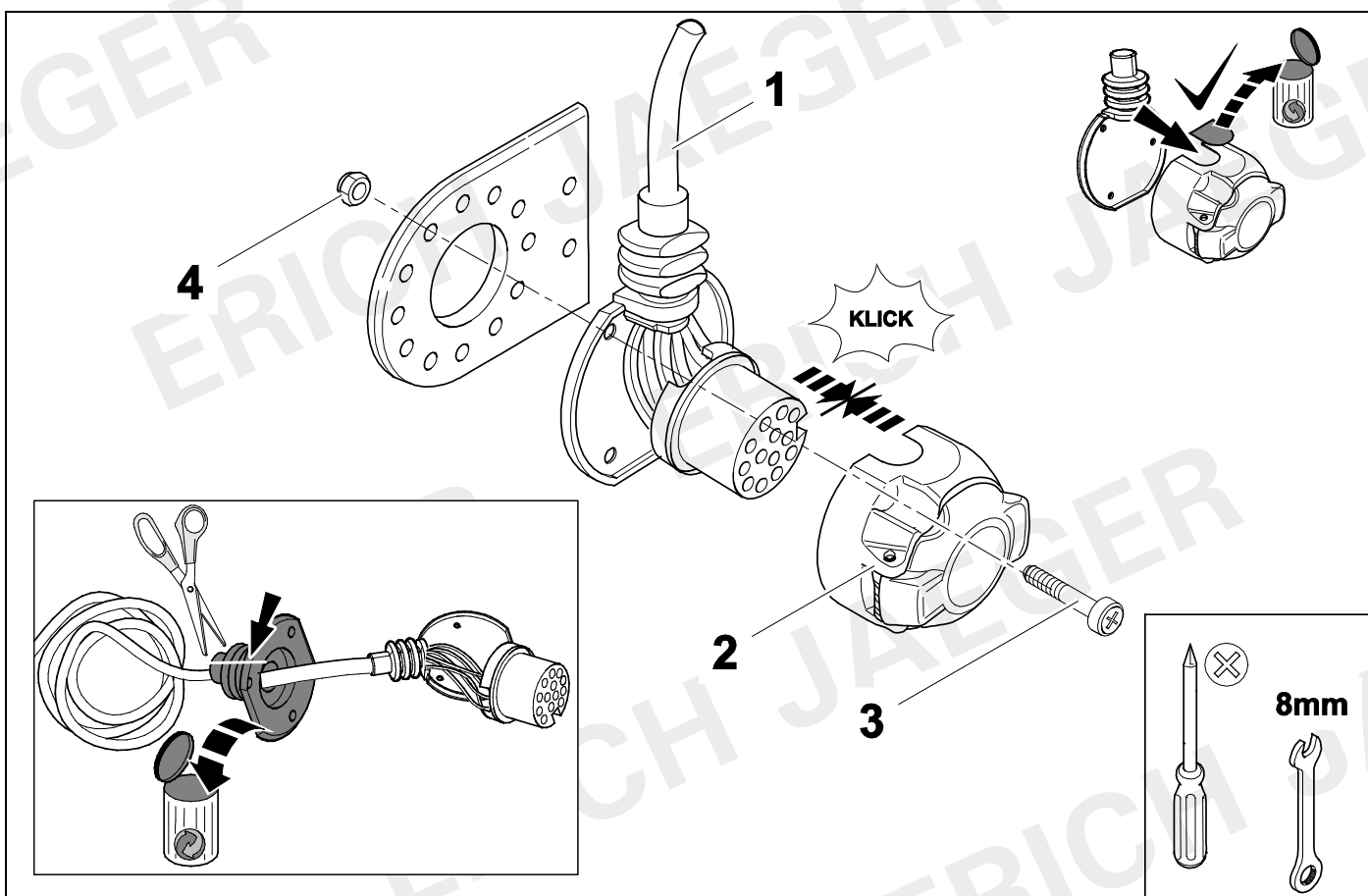



7 + 13 Pin			13 Pin		
1	bk/wh			bu/rd	8
2	gy			rd/bu	9
3	bn			ye	10
4	bk/gn			bn/gn	11
5	gy/rd		-/-	no	12
6	bk/rd			bn	13
7	gy/bk				

55	bk	wh	gy	gn	rd	bu	ye	bn	pu	or	no
D	schwarz	weiß	grau	grün	rot	blau	gelb	braun	violett	orange	nicht belegt
GB	black	white	grey	green	red	blue	yellow	brown	purple	orange	not occupied
F	noir	blanc	gris	vert	rouge	bleu	jaune	brun	violet	orange	inutilisé
NL	zwart	wit	grijs	groen	rood	blauw	geel	bruin	violet	oranje	niet aangesloten
DK	sort	hvid	grå	grøn	rød	blå	gul	brun	violet	orange	ikke anvendt
N	svart	hvit	grå	grønn	rød	blå	gul	brun	fiolett	oransje	ikke i bruk
S	svart	vit	grå	grön	röd	blå	gul	brun	violett	orange	ej använd
FIN	musta	valkoinen	harmaa	vihreä	punainen	sininen	keltainen	ruskea	violetti	oranssi	ei varattu
I	nero	bianco	grigio	verde	rosso	blu	giallo	marrone	viola	arancione	libero
E	negro	blanco	gris	verde	rojo	azul	amarillo	marrón	violeta	anaranja-do	no ocupado
P	preto	branco	cinzento	verde	vermelho	azul	amarelo	castanho	violeta	laranja	não ocupado
GR	μαύρος	λευκός	Γκρι	πράσινος	κόκκινος	μπλε	κίτρινος	καφέ	Μωβ	πορτοκαλί	δεν είναι καταλημμένος
PL	czarny	biały	szary	zielony	czerwony	niebiesko	żółty	brazowy	fioletowy	pomarańczowy	wolny
CZ	černý	bílý	šedý	zelený	červený	modrý	žlutý	hnědý	fialový	oranžový	neobsazen
TR	siyah	beyaz	gri	yeşil	kırmızı	mavi	sarı	kahverengi	mor	portakal rengi	boş
H	fekete	fehér	szürke	zöld	piros	kék	sárga	barna	ibolyakék	narancssárga	nem foglalt
HR	crno	bijelo	sivo	zeleno	crveno	plavo	zuto	smeđe	ljubičasto	narandasto	nije zauzeto
BUL	черен	бял	сив	зелен	червен	син	жълт	кафяв	виолетов	оранжев	свободно
RO	negru	alb	gri	verde	roșu	albastru	galben	maro	violet	portocaliu	liber
RU	черный	белый	серый	зеленый	красный	голубой	жёлтый	коричневый	пурпурный	оранжевый	свободно
LT	juoda	balta	pilka	žalia	raudona	mėlyna	geltona	ruda	purpurinė	oranžinė	laisva
LV	mēlna	balta	pelēka	zaļa	sarkana	zila	dzeltena	brūna	purpur-sarkana	oranža	brīvs
EST	must	valge	hall	roheline	punane	sinine	kollane	pruun	purpur-punane	oraanz	vaba
SLO	črna	bela	siva	zelena	rdeča	modra	rumena	smeđ	vijoličast	oranžen	ni zasedeno
SK	čierny	biely	šedý	zelený	červený	modrý	žltý	hnědý	fialový	pomaraňový	neobsadený

56

748401

			ERICH JAEGER Artikelnummer: ERICH JAEGER part number:	721334

57

Radio code

58 CHECK

OK

59

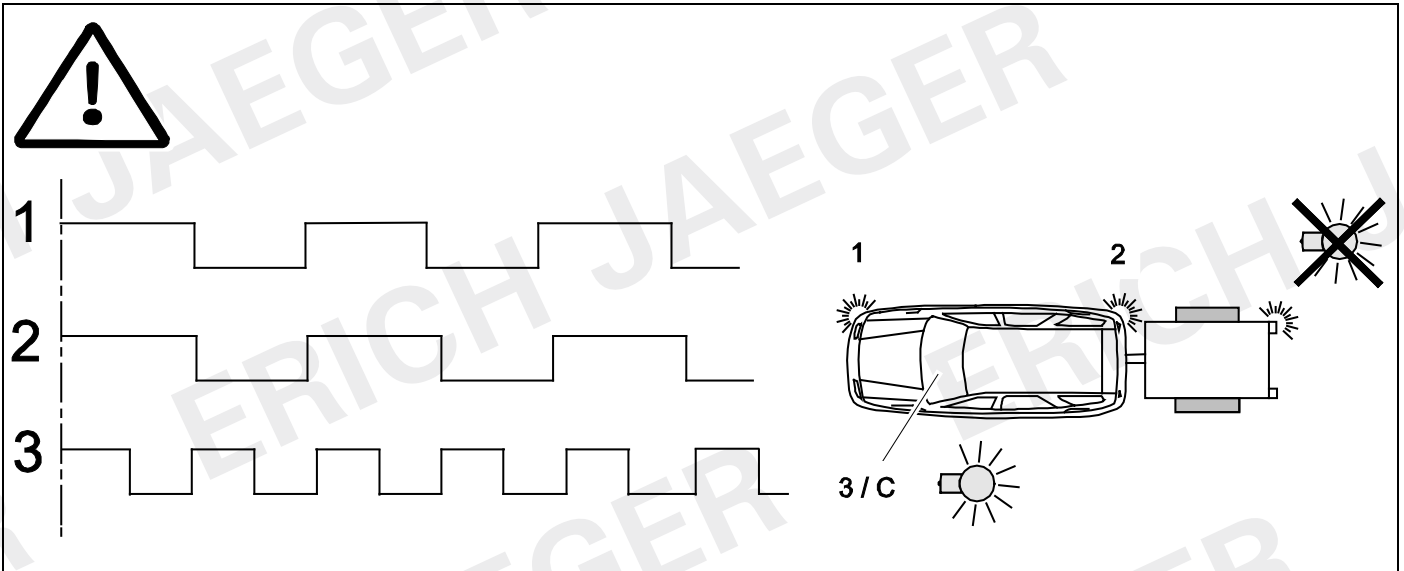

60

PDC

OPTION 1

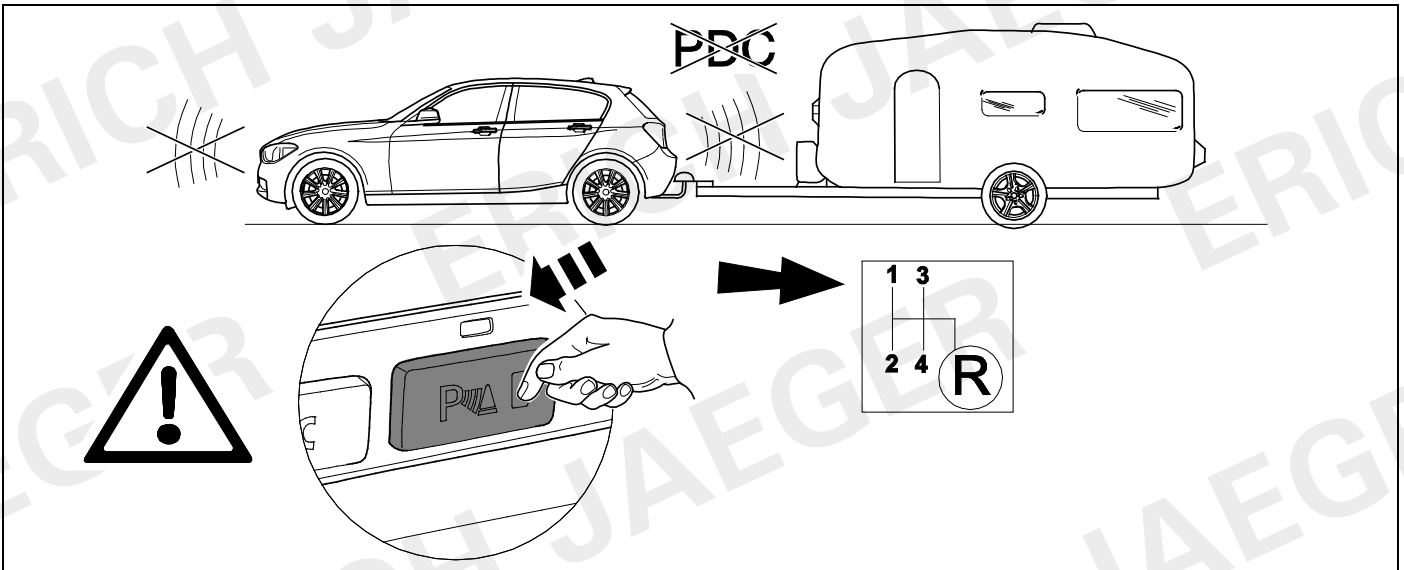

61

PDC

OPTION 2

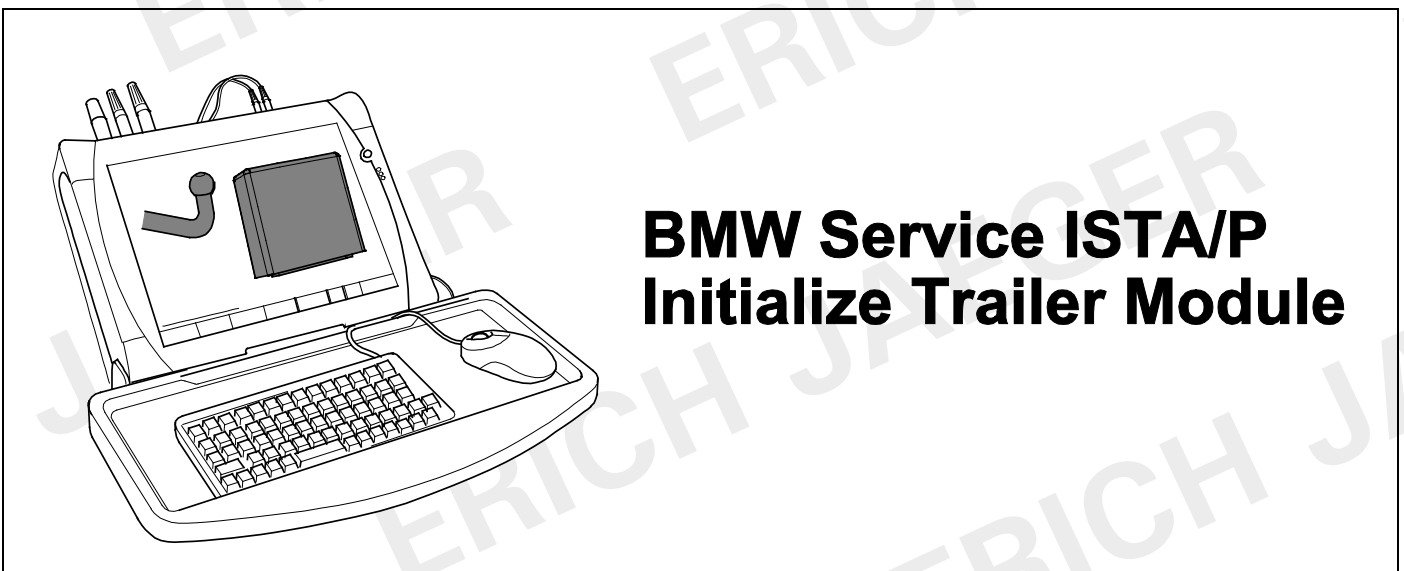

62

PDC

OPTION 2

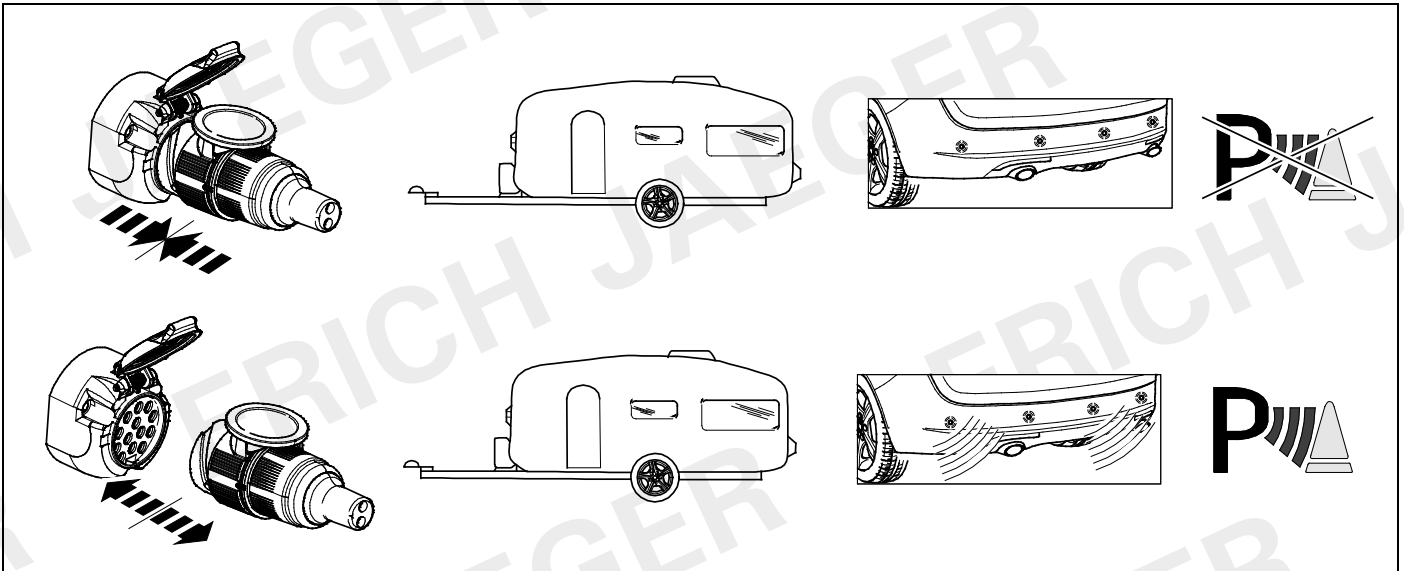

63



41

42

45

46

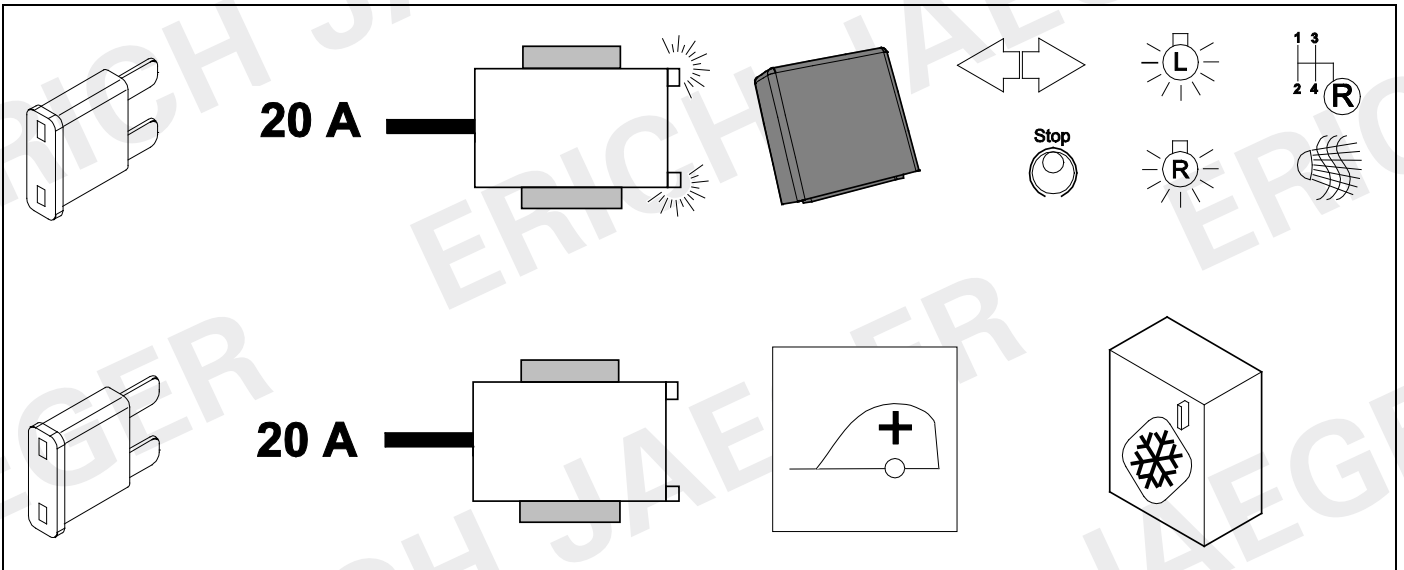

64

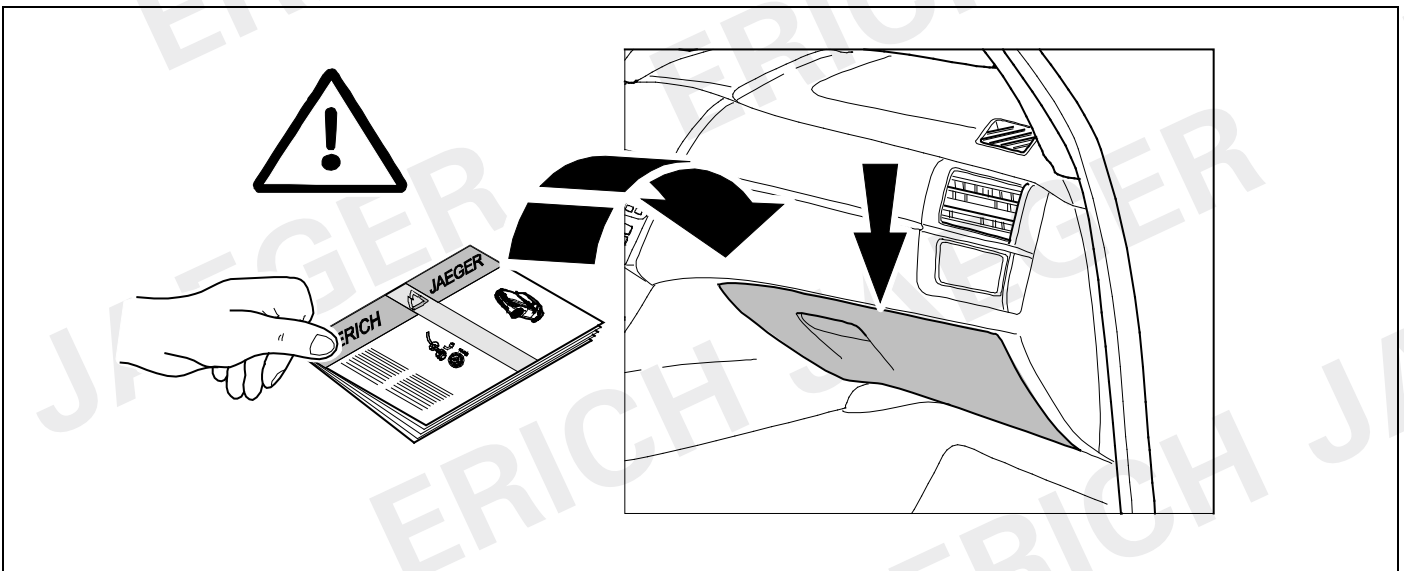

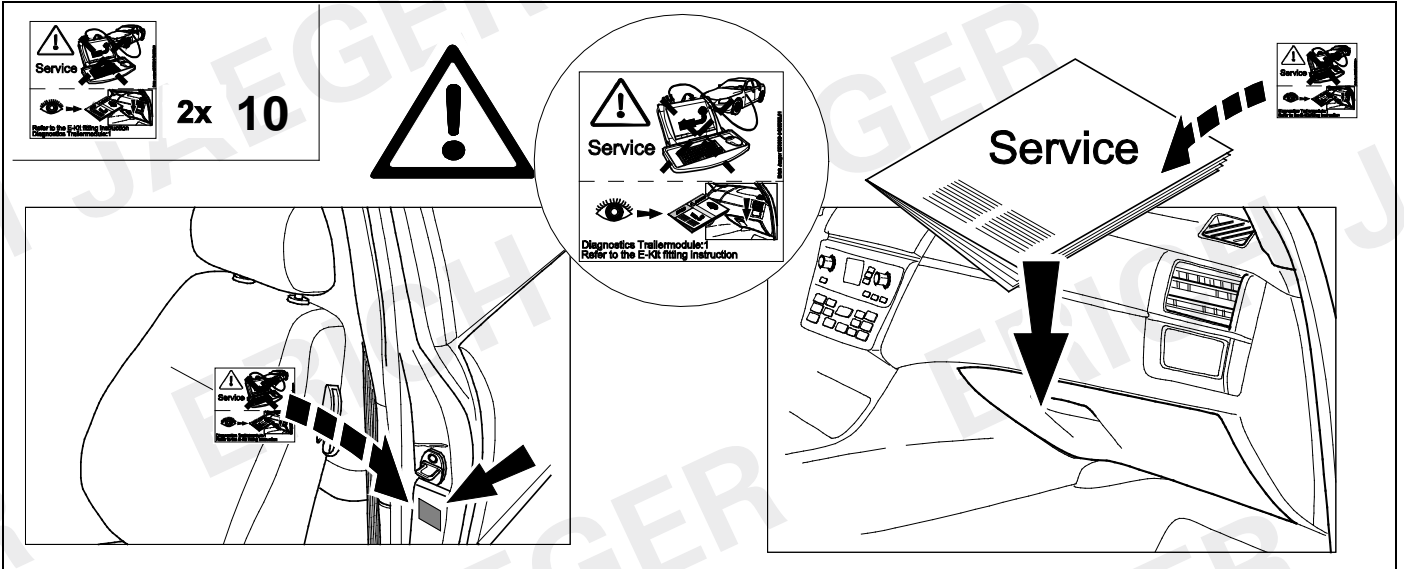

D	Änderungen bezüglich Konstruktion, Ausstattung Farbe sowie Irrtum vorbehalten. Angaben und Abbildungen unverbindlich	PL	Zastrzega się prawo do zmian dot. konstrukcji, wykończenia, kolorystyki oraz pomylek. Dane i ilustracje niewiążące.
GB	Subject to change in terms of construction, equipment and colour, and may contain errors. The information and illustrations are non-binding.	TR	Tasarım, donanım ve renk bakımından değişiklik yapma hakkı ve hata ve eksiklik mahfuzdur. Veriler ve resimler bağlayıcı değildir.
F	Sous réserve de modifications de la construction, de l'équipement, de la couleur et sous réserve d'erreurs. Les indications et les illustrations sont sans engagement.	H	A szerkezet, a kivétel és a szín változtatása, valamint a változások joga fenntartva. Az adatok és az ábrák nem kötelező érvényűek.
NL	Wijzigingen met betrekking tot constructie, uitvoering en kleur evenals vergissingen voorbehouden. Gegevens en afbeeldingen niet bindend.	HR	Pravo promjena u svezi konstrukcije, opreme, boje kao i zabune oridžavamo. Podaci i ilustracije su neobavezne.
DK	Ændringer med hensyn til konstruktion, udstyr, farver samt fejl forbeholdes. Oplysninger og illustrationer er uforpligtende.	BUL	Запазени права по отношение на конструкцията, обзавеждането, цвета и грешки. Данните и изображенията не са обвързващи.
N	Ændringer angående konstruksjon, utstyr, farge og feiltagelse forbeholdes. Oplysninger og illustrasjoner uforbindtlig.	RO	Ne rezervăm dreptul unor modificări ale construcției, dotării, culorii și dreptul la erori Datele indicate și imaginile sunt orientative.
S	Med reservation för ändringar vad det gäller konstruktion, utrustning, färg samt för misstag. Uppgifterna och bilderna är inte bindande.	RU	Права на внесение изменений относительно конструкции, оснащения, окраски, а также на ошибки сохраняются. Данные и иллюстрации имеют примерный характер.
FIN	Pidätämme oikeuden rakennetta, varustusta, väriä koskeviin sekä erehdyksestä johtuviin muutoksiin. Tiedot ja kuvat eivät ole sitovia.	LT	Pasiliekaama konstrukcijos, įrangos bei reikmenų, spalvos pakeitimų ir klaidų teisė. Duomenys ir iliustracijos neįpareigojantys.
I	Con riserva di modifiche relative a progettazione, dotazione, colore ed errori. Le indicazioni e figure sono fornite senza impegno.	LV	Tiek paturētas tiesības uz konstrukcijas, iekārtu, krāsu izmaiņām, kā arī kļūdīšanās. Dati un attēli bez saistībām.
E	Reservadas las modificaciones respecto a diseño, equipamiento, color, así como error. Indicaciones y figuras sin compromiso.	EST	Konstruksiooni, varustuse ja võervi osas muudatused ning eksimine lubatud. Andmed ja joonised on mittesiduvad.
P	Reservamos o direito de alterações relativamente ao desenho, equipamento, cor, bem como de erro. Os dados e as gravuras não implicam compromisso da nossa parte.	SLO	Zadržana pravica do sprememb glede konstrukcije, opreme, barve ter pomote. Podatki in slike so neobvezne.
GR	Διατηρώνουμε κάθε επιφύλαξη ως προς αλλαγές σε σχέση με κατασκευή, εξοπλισμό, διαρρύθμιση, χρωματισμούς και λάθη παραδρομής.	SK	Zmeny, ktoré sa týkajú konštrukcie, vybavenia, farby, ako aj omyly sú vyhradené. Údaje a zobrazenia sú nezáväzné.
CZ	Změny, týkající se konstrukce, vybavení, barvy, jakož i omyly jsou vyhrazeny. Údaje a vyobrazení jsou nezávazné.		

ERICH JAEGER Artikelnummer: ERICH JAEGER part number:	311069	ERICH JAEGER Artikelnummer: ERICH JAEGER part number:	311105
--	---------------	--	---------------

